



ᐅᖃᐅᓯᖃᖃ ᖃᐅᓴᓴᖃᖃ

ᐅᓴᓴᖃ:

ᐅᓴᓴᖃᖃ ᖃᐅᓴᓴᖃᖃ ᖃᐅᓴᓴᖃᖃ 2



σΛϵΝΔϵΔϵ ΔΔΔΔΔ

ΔΔΔΔΔ ΔΔΔΔΔ
ϵΔΔΔΔΔ 2

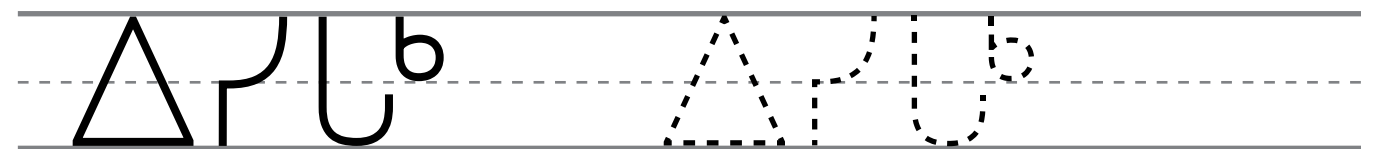
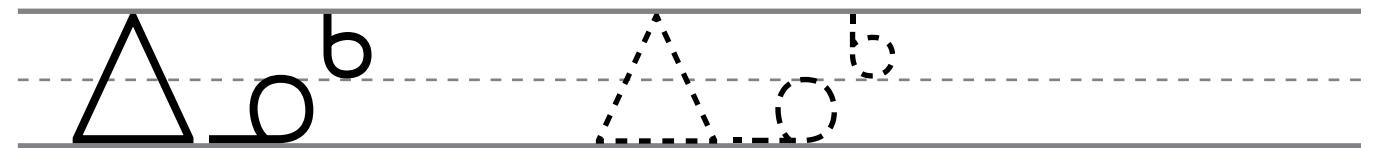
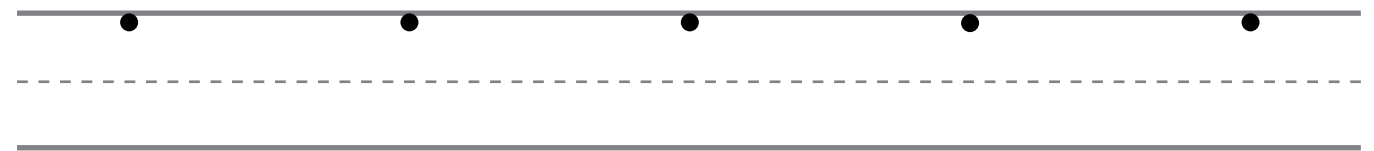
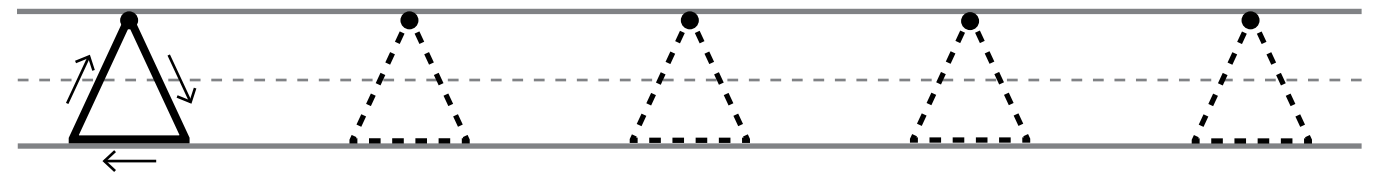
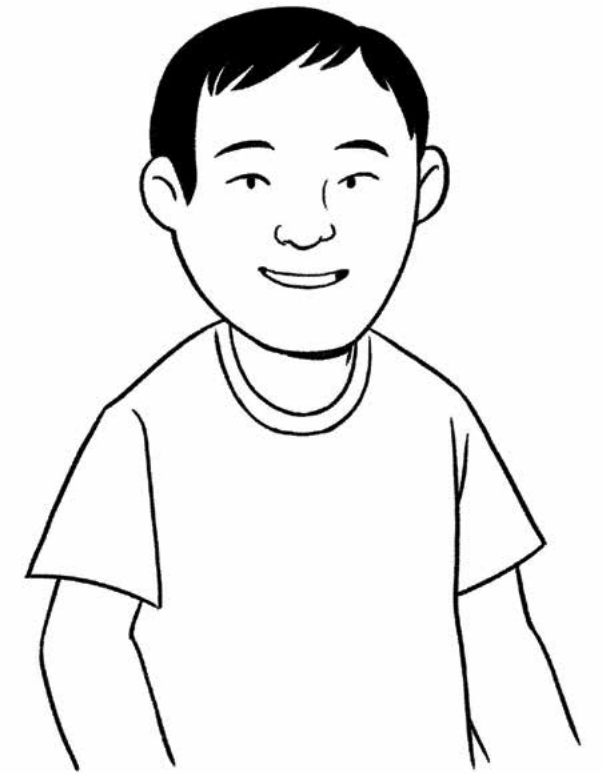
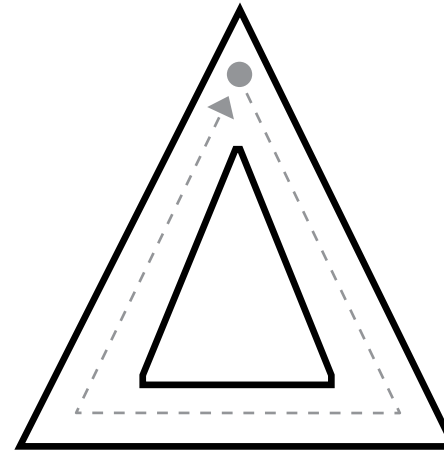

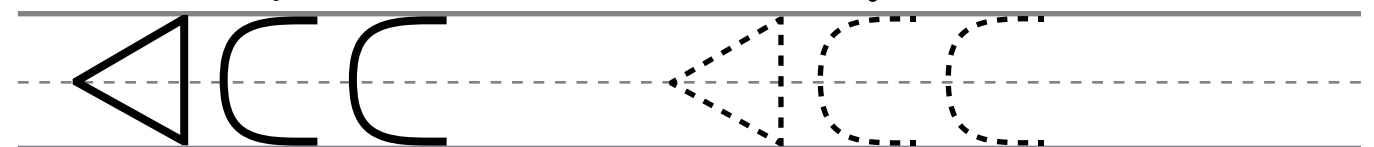
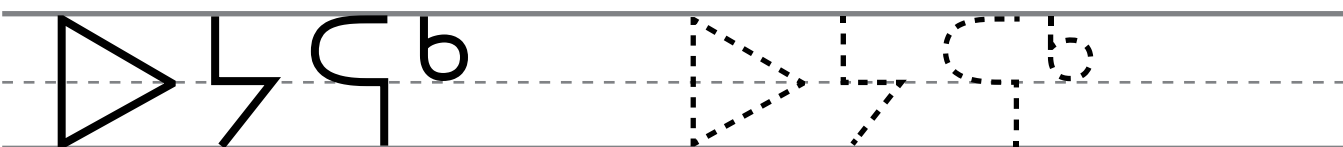
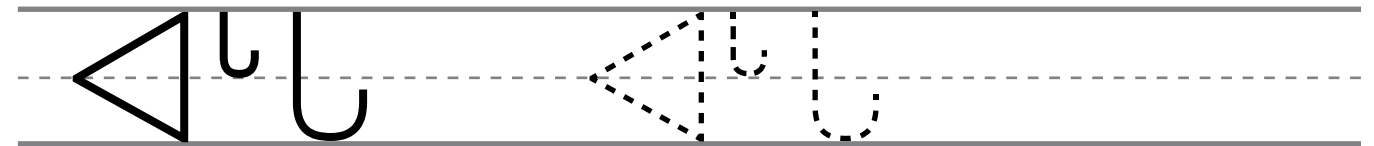
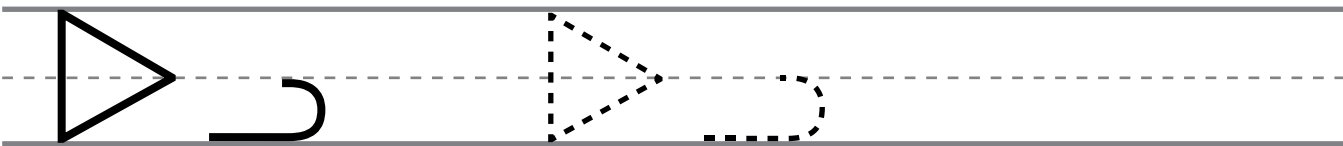
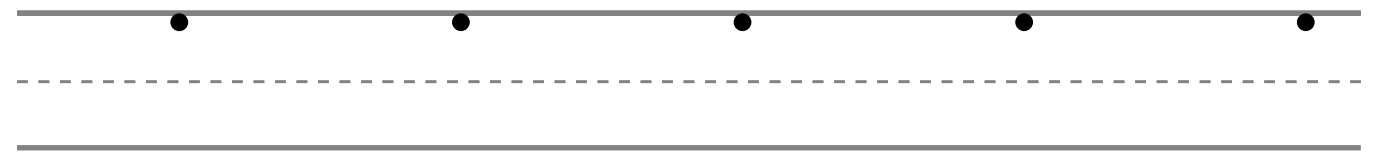
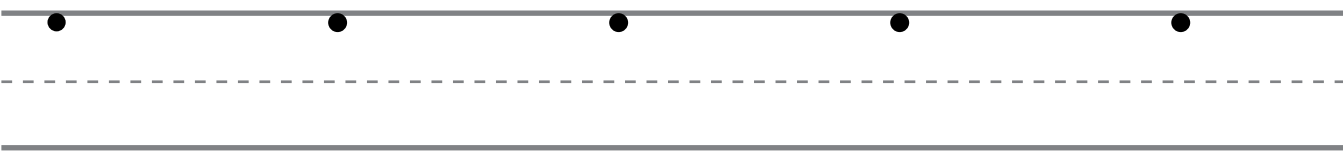
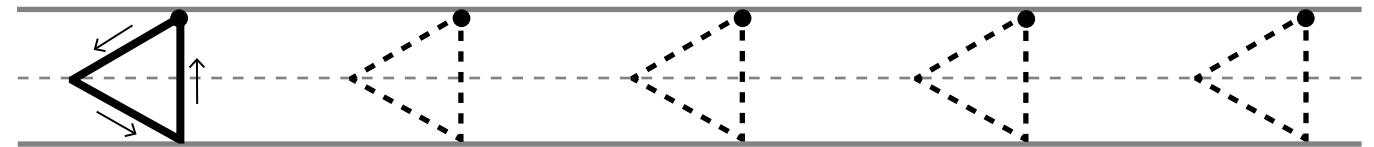
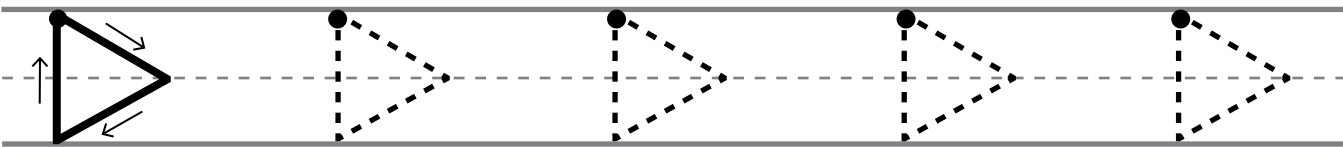
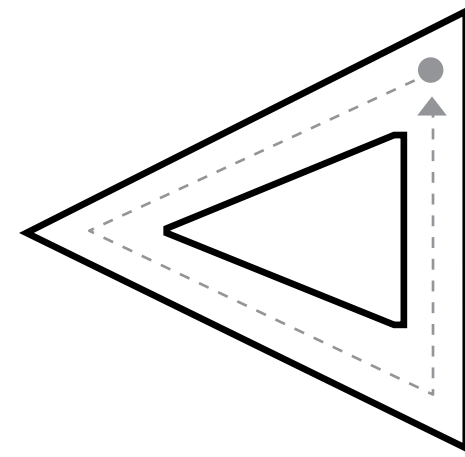
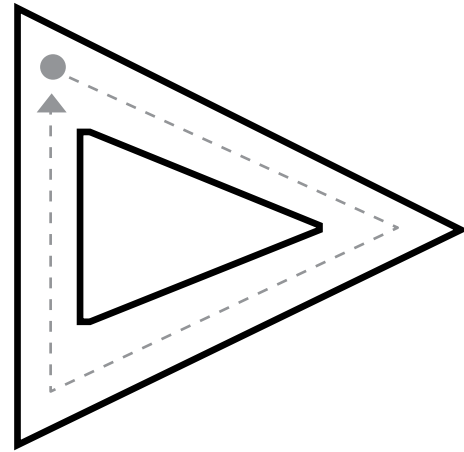
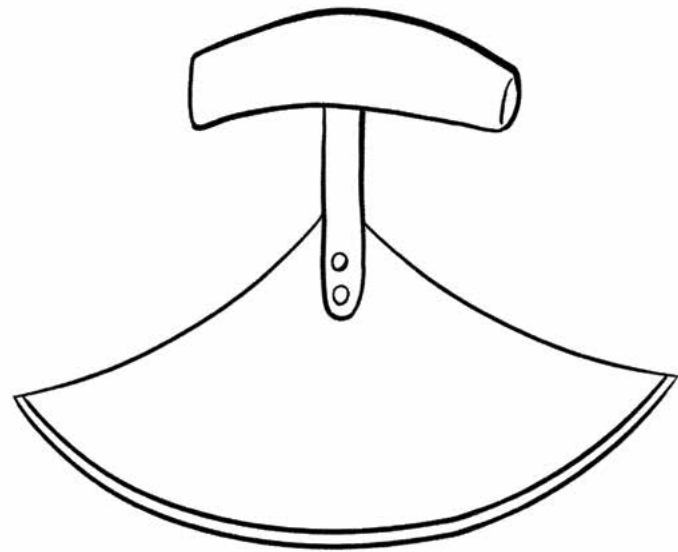

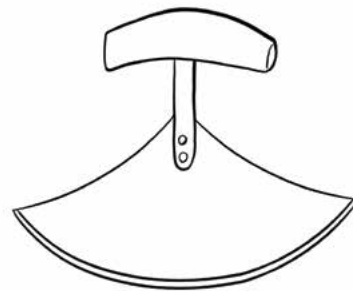

Handwriting practice for uppercase letter 'A' on page 4. The page contains seven rows of three-line guides (top, middle dashed, bottom). Each row starts with a solid 'A' showing stroke order: 1. diagonal down-right, 2. diagonal down-left, 3. horizontal across the top. This is followed by a dashed 'A' for tracing, and then five dots on the top line for independent practice.

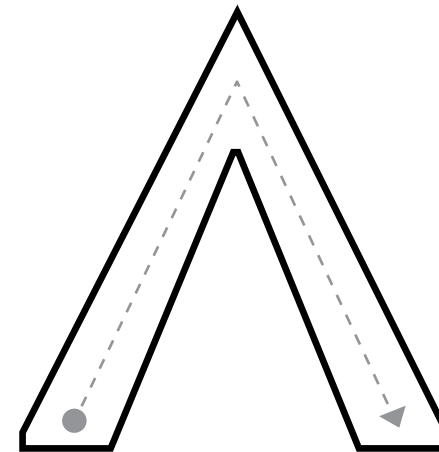

Handwriting practice for uppercase letter 'A' on page 5. The page contains four rows of three-line guides. The first row shows a solid 'A' with stroke order arrows, followed by four dashed 'A's for tracing. The second row contains five dots on the top line. The third row shows the Inuktitut syllable 'Aq' followed by a dashed 'Aq' for tracing. The fourth row shows the Inuktitut syllable 'Ab' followed by a dashed 'Ab' for tracing.

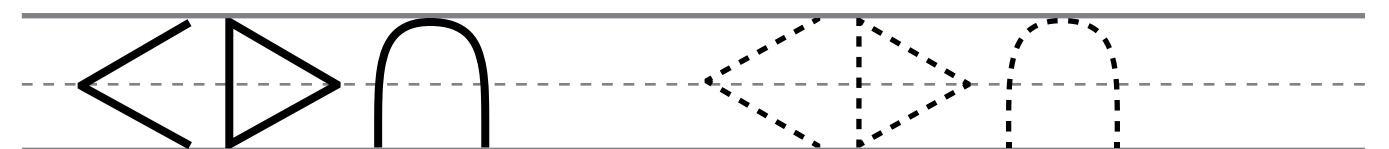
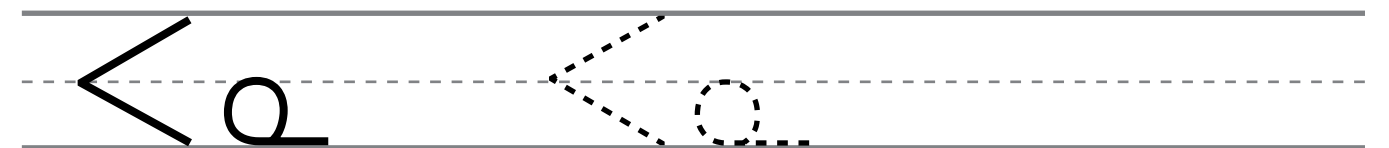
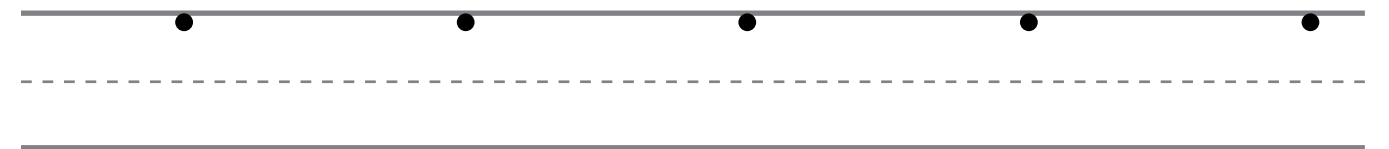
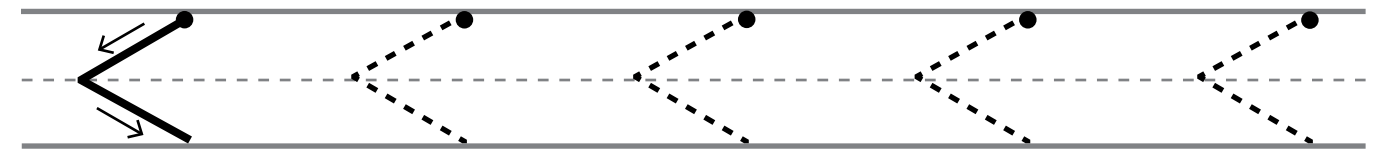
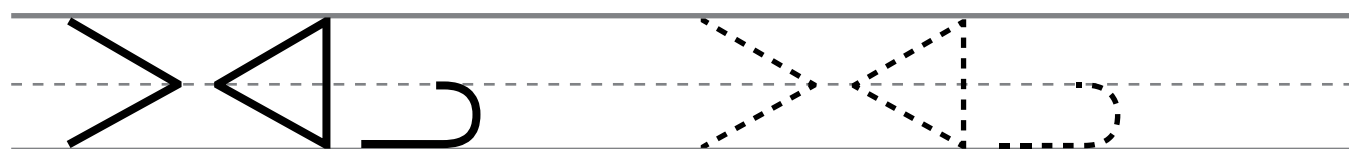
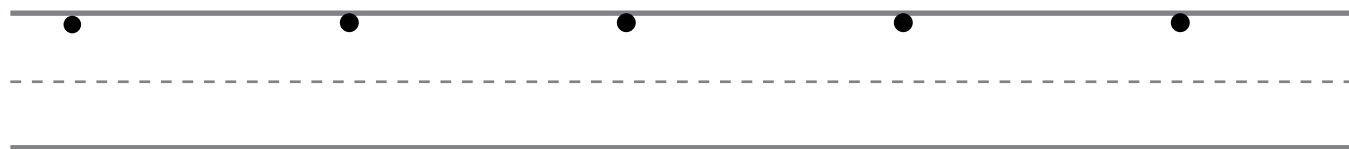
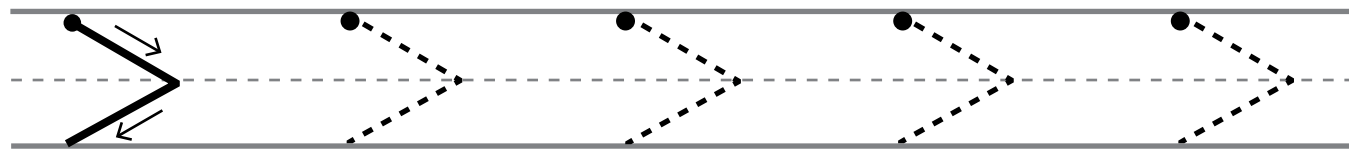
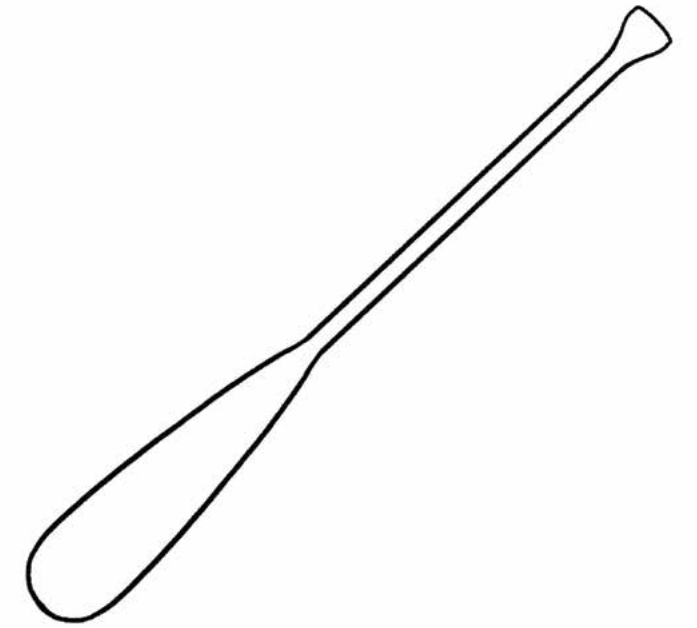
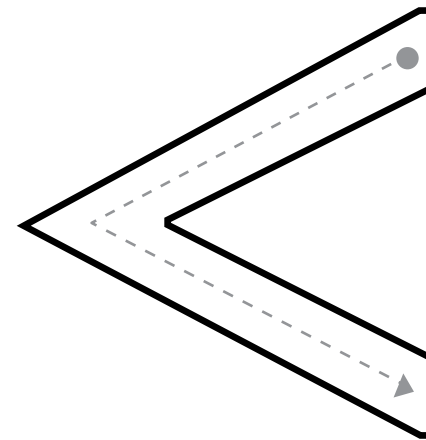
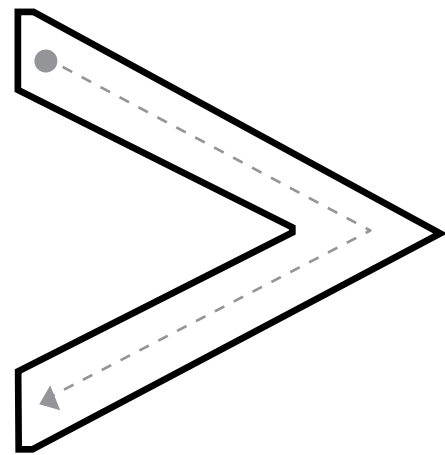
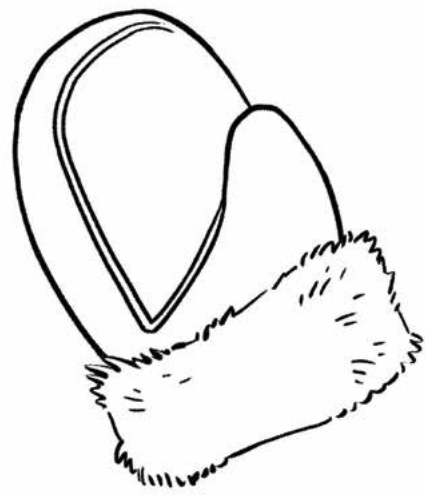

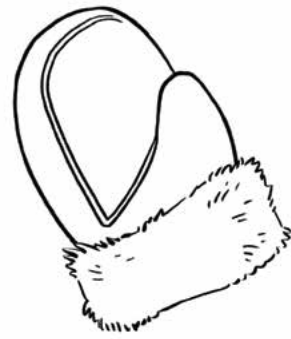

Handwriting practice for the letter 'A' on a three-line grid. The first row shows a solid 'A' with directional arrows and a dashed 'A' for tracing, followed by five dots on the baseline. The second row shows a solid 'A' with directional arrows and a dashed 'A' for tracing, followed by five dots. The third row shows a solid 'A' with directional arrows and a dashed 'A' for tracing, followed by five dots. The fourth row shows a solid 'A' followed by five dots. The fifth row shows a solid 'A' followed by five dots. The sixth row shows a solid 'A' followed by five dots.

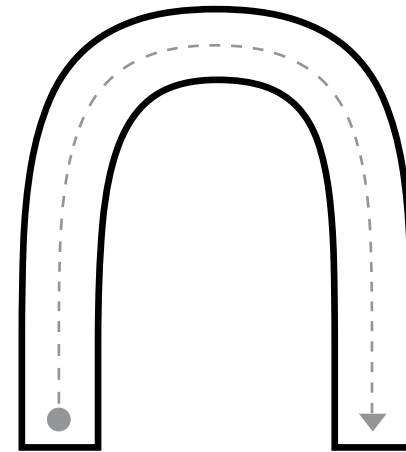

Handwriting practice for the letter 'U' on a three-line grid. The first row shows a solid 'U' with directional arrows and four dashed 'U's for tracing, each with a dot on the baseline. The second row shows five dots on the baseline. The third row shows a solid 'U' followed by a dashed 'U' for tracing, each with a dot on the baseline. The fourth row shows a solid 'U' followed by a dashed 'U' for tracing, each with a dot on the baseline.

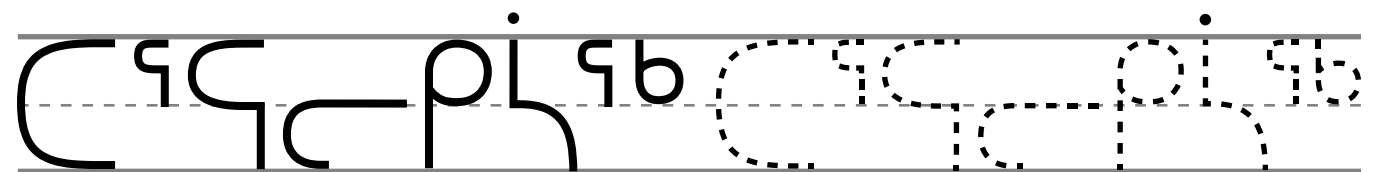
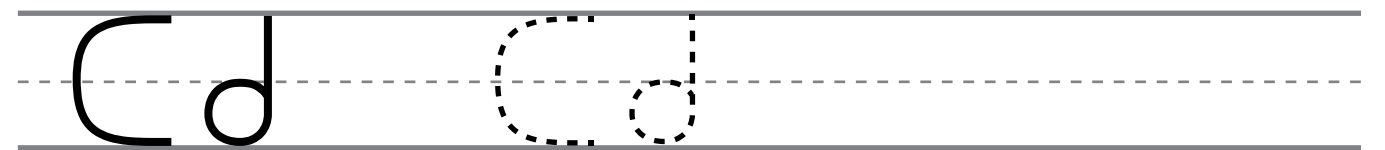
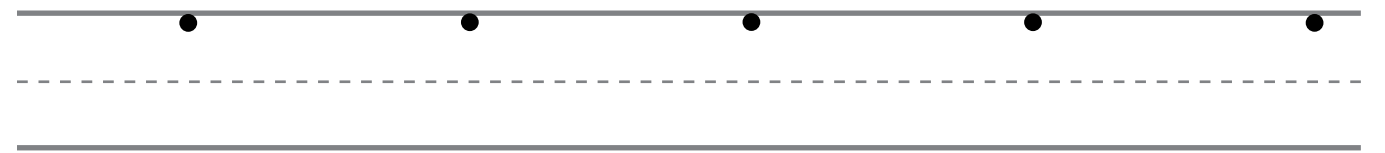
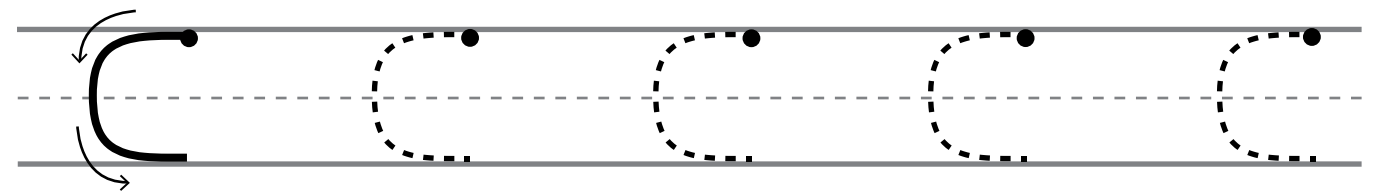
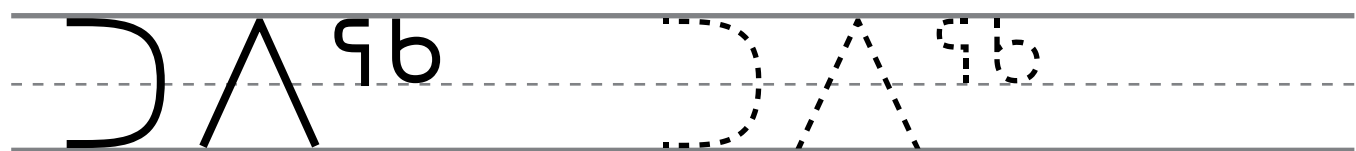
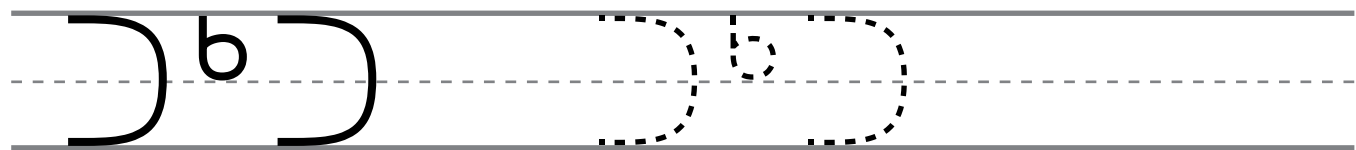
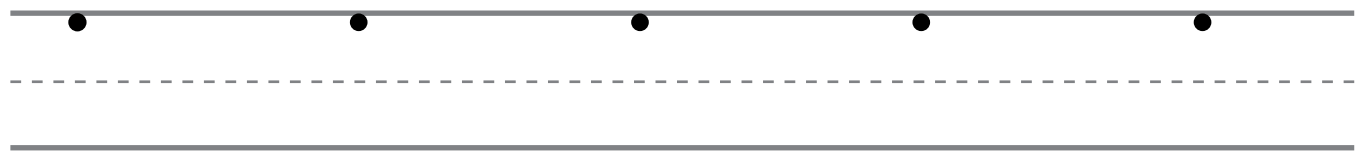
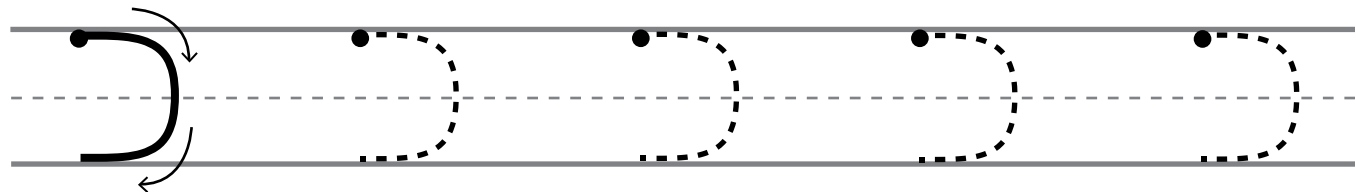
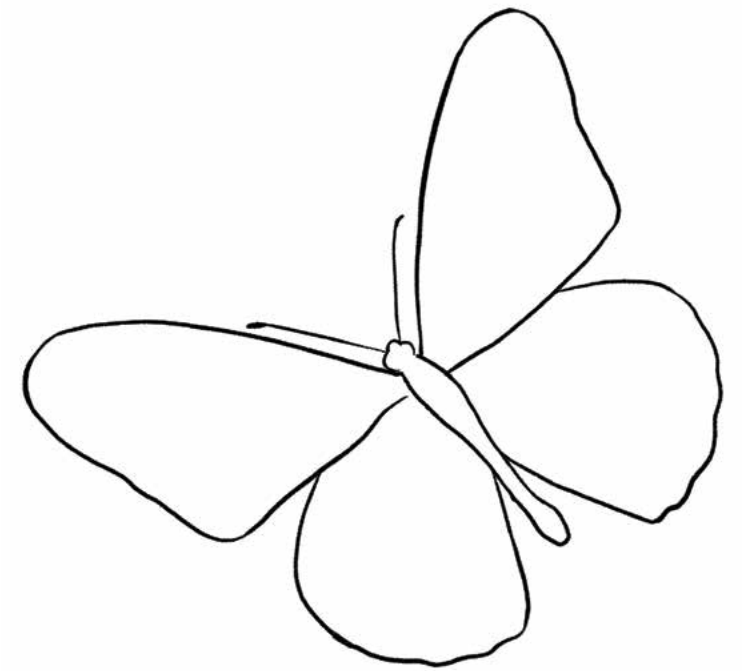
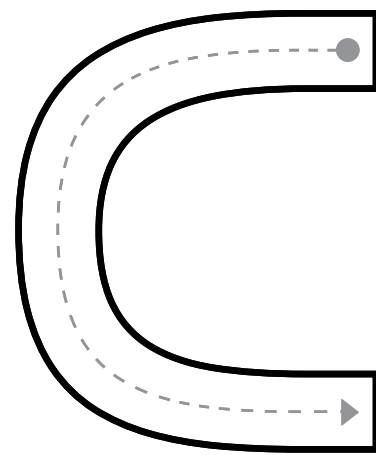
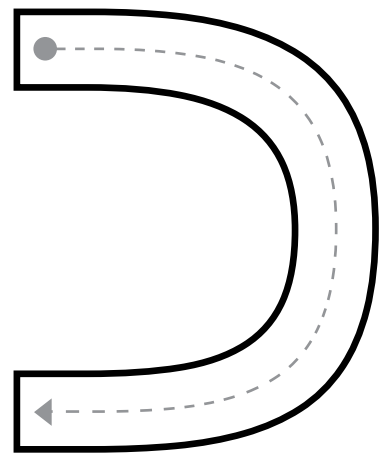
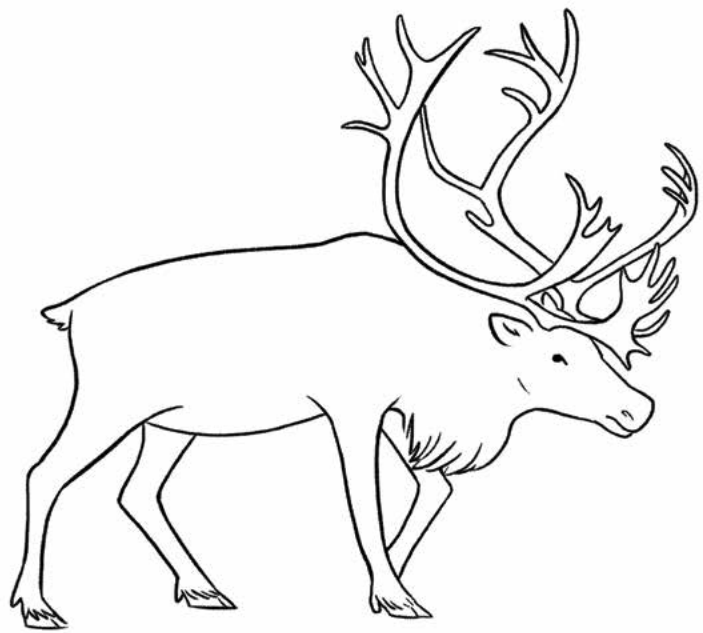

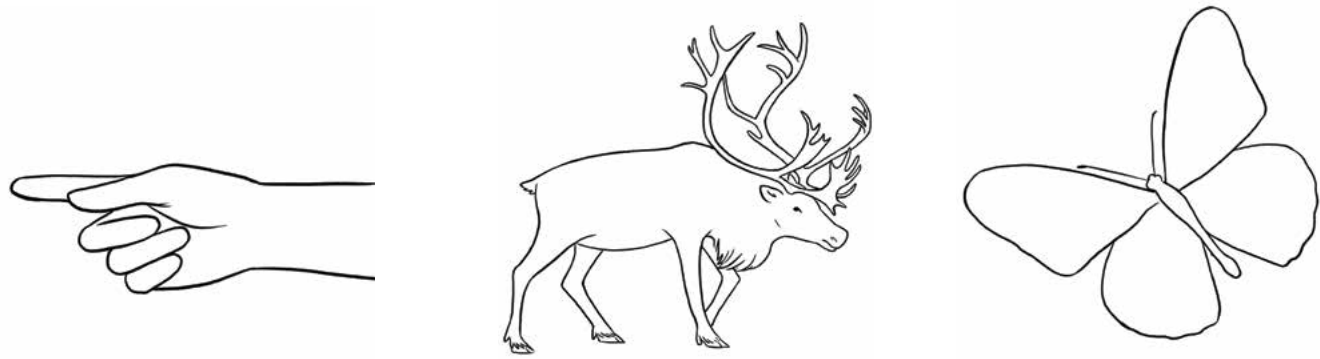

Handwriting practice for uppercase letters P, U, C, and A. Each letter is shown on a set of three horizontal lines (top, middle-dashed, bottom). The first row shows uppercase P with stroke order arrows and a dashed version for tracing, followed by five dots on the middle line. The second row shows uppercase U with stroke order arrows and a dashed version for tracing, followed by five dots on the middle line. The third row shows uppercase C with stroke order arrows and a dashed version for tracing, followed by five dots on the middle line. The fourth row shows uppercase A with five dots on the middle line.

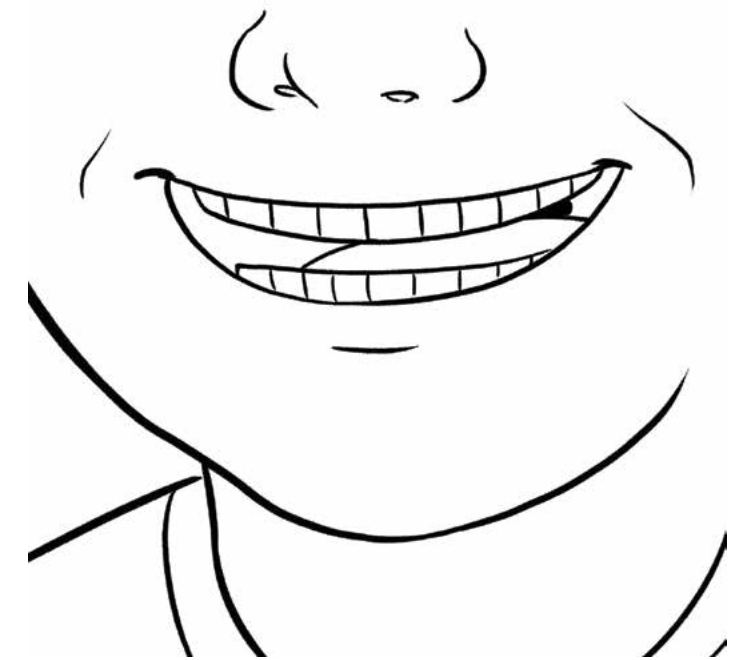
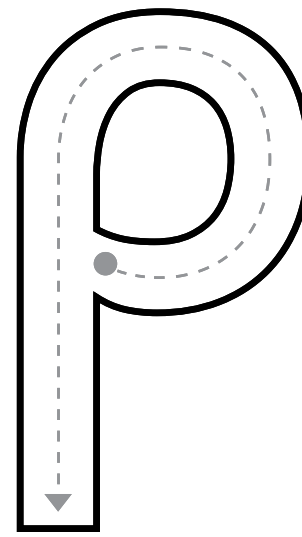

Handwriting practice for lowercase letters p and a. The first row shows lowercase p with stroke order arrows and a dashed version for tracing, followed by five dashed p's for tracing. The second row shows five dots on the middle line. The third row shows lowercase a with a dashed version for tracing, followed by a dashed a with a triangle pointing to its right side. The fourth row shows lowercase p followed by lowercase a, with a dashed version of each for tracing.

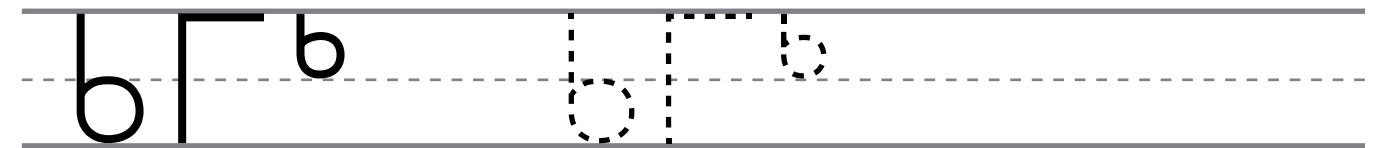
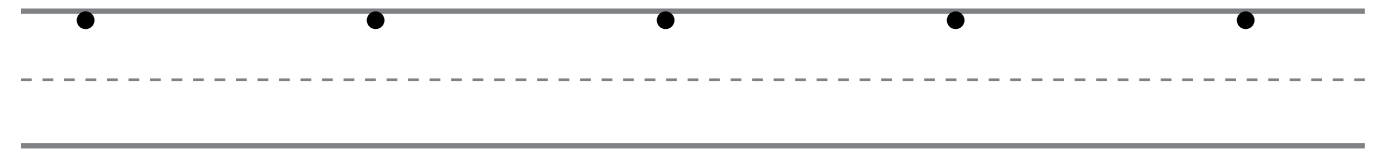
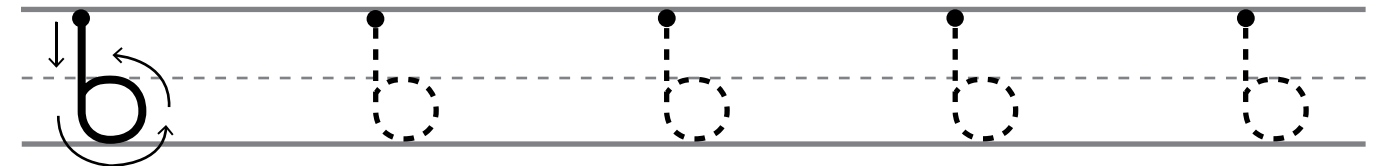
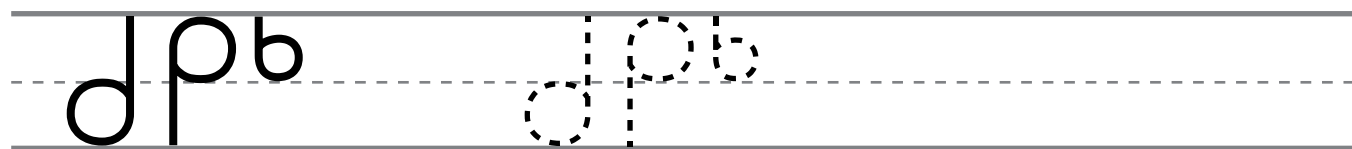
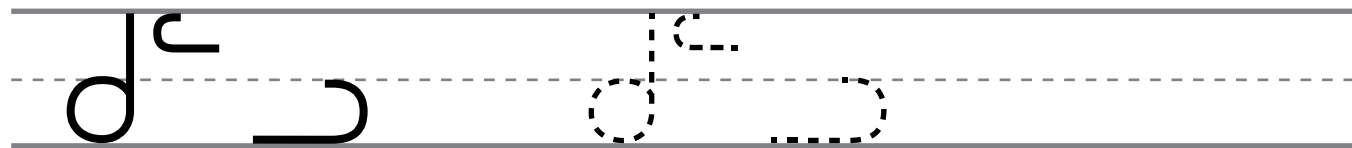
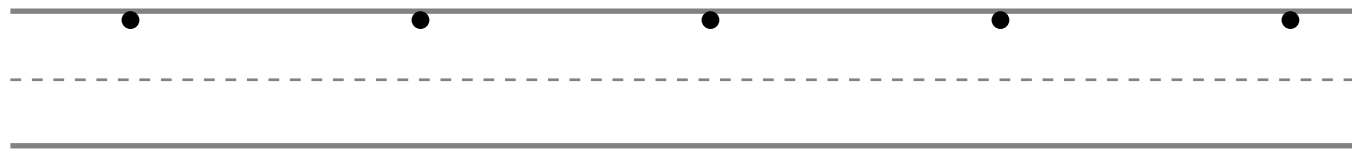
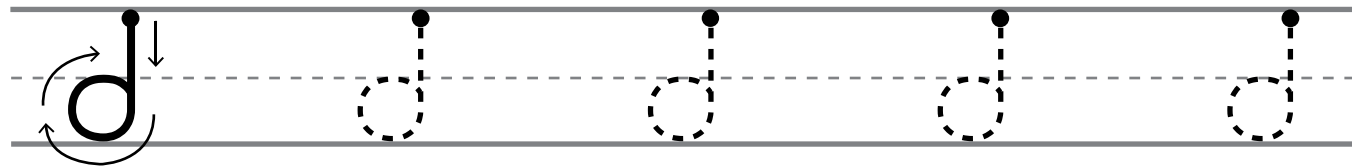
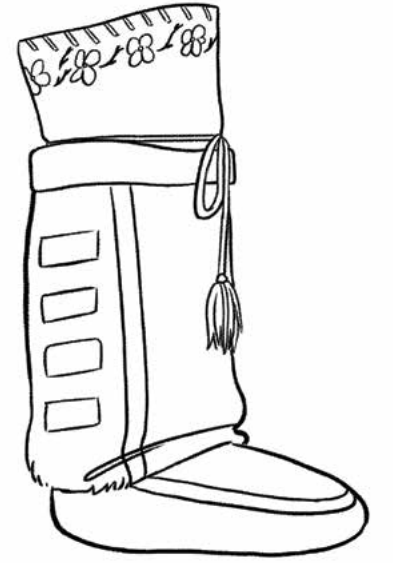
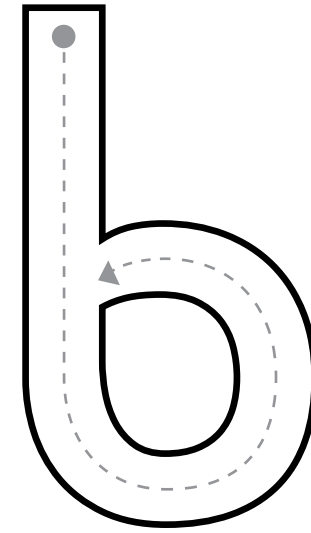
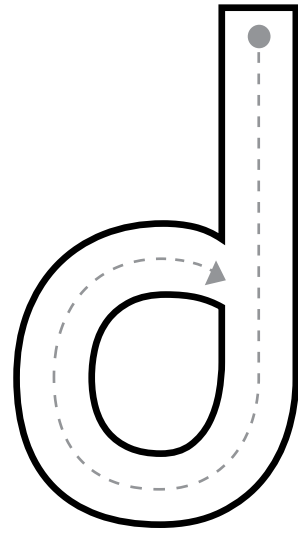
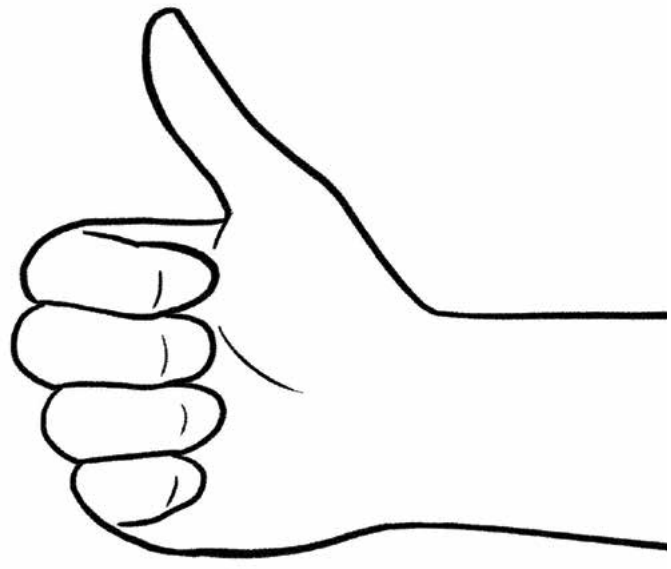

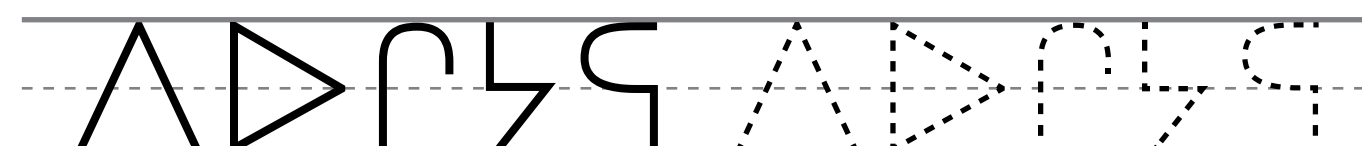
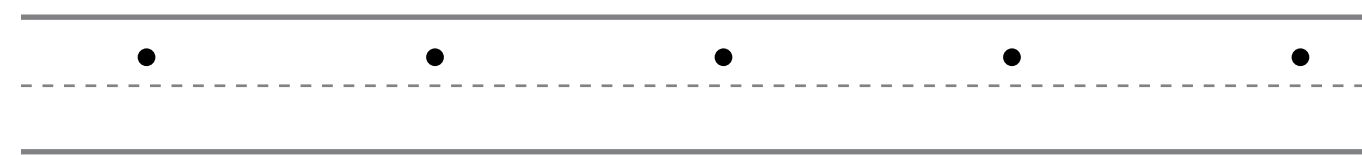
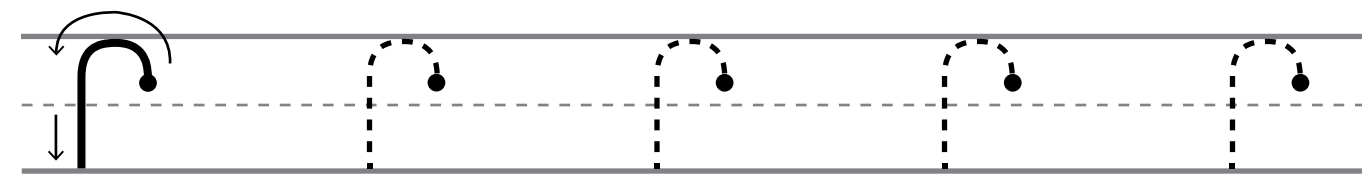
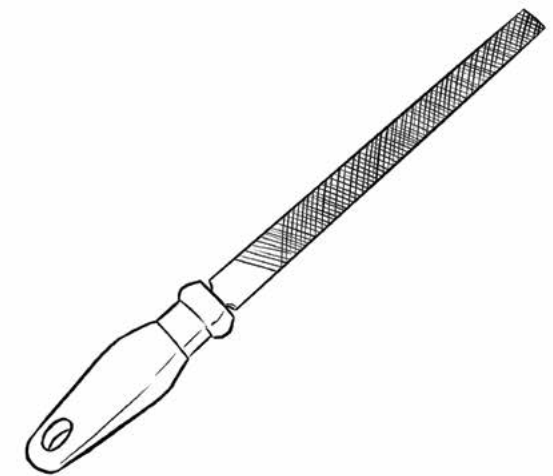
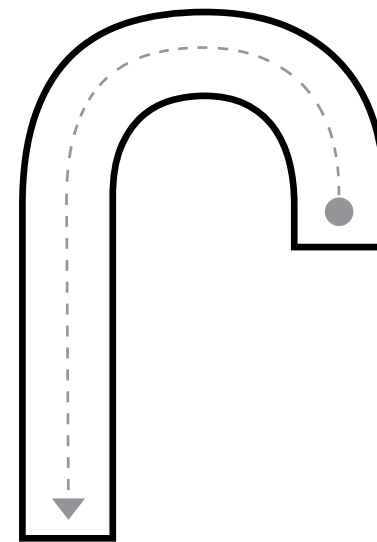
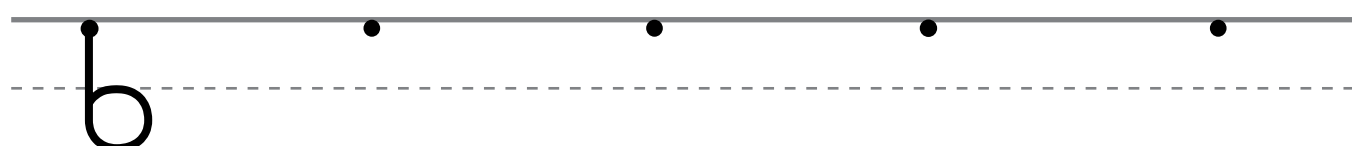
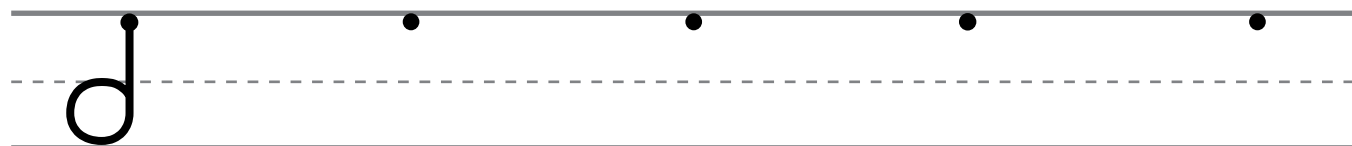
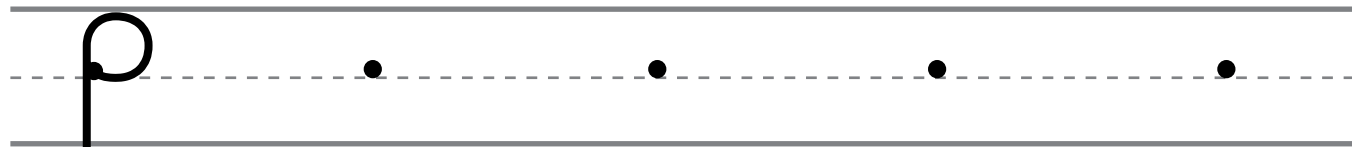
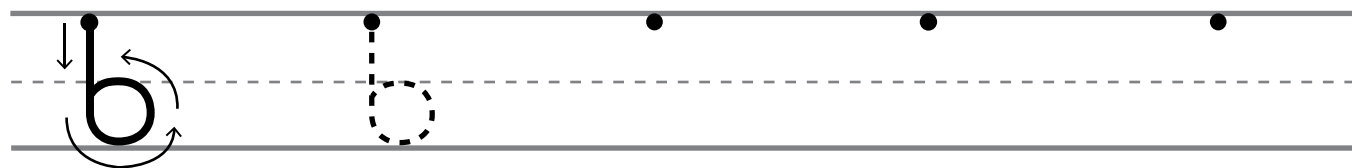
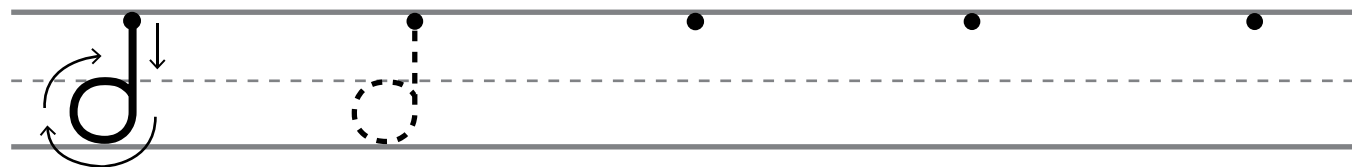
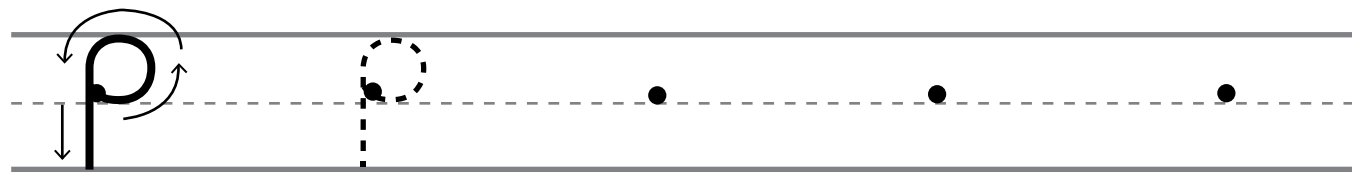
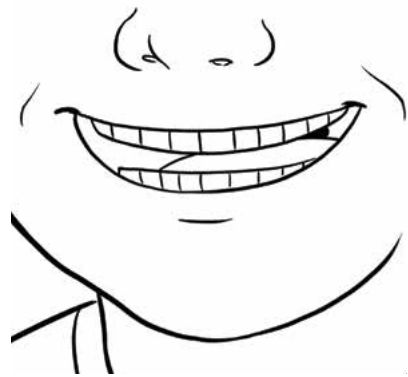

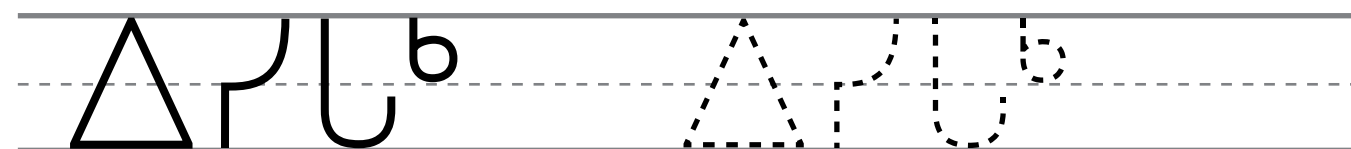
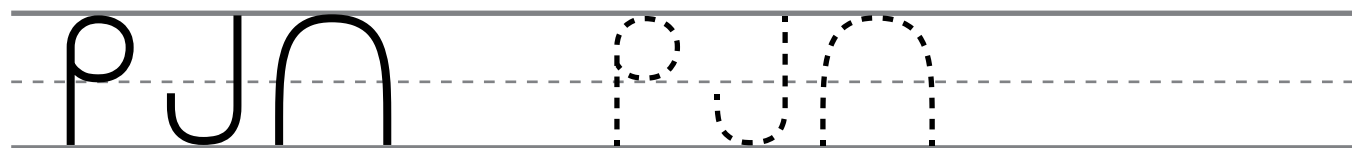
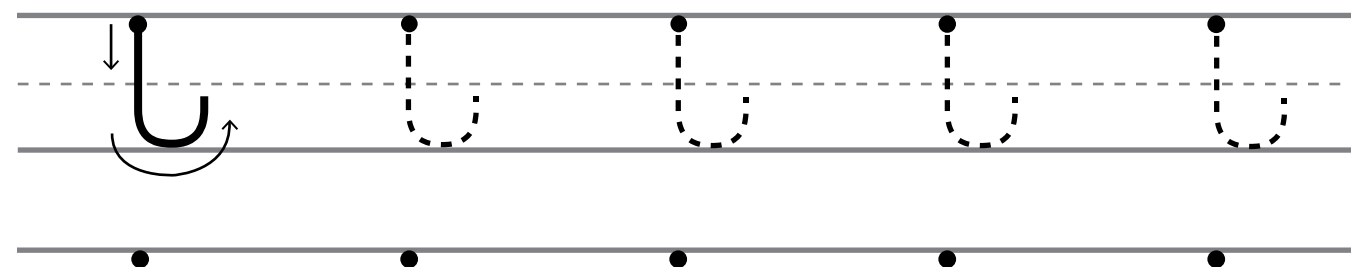
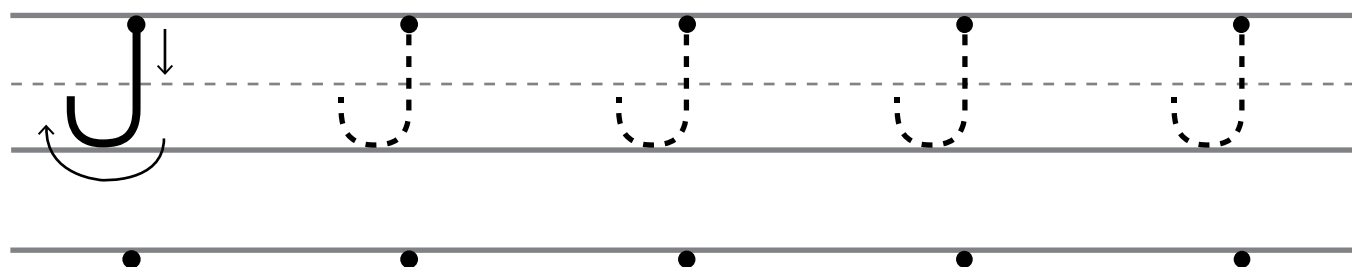
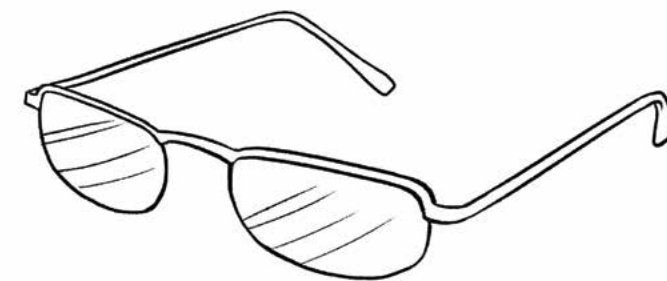
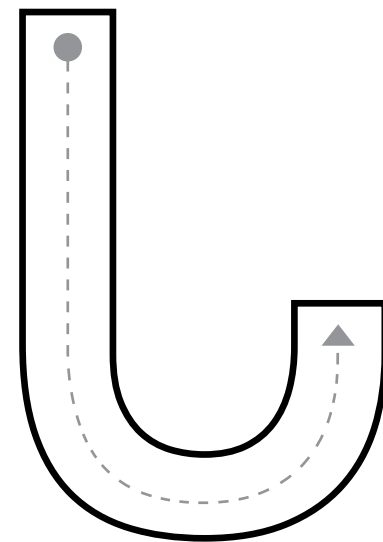
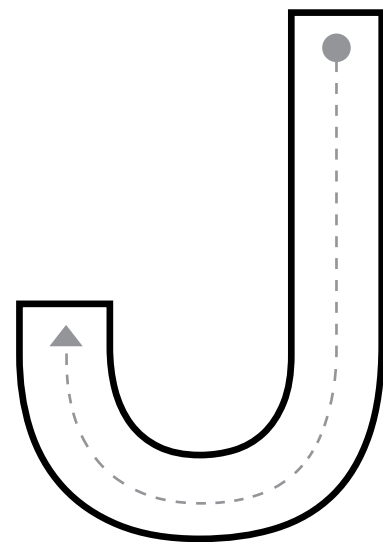
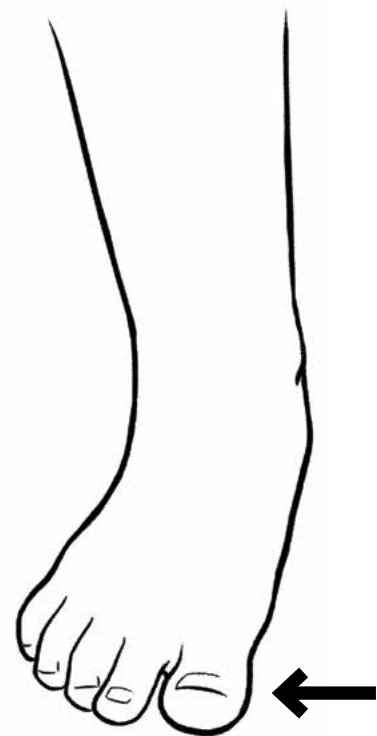

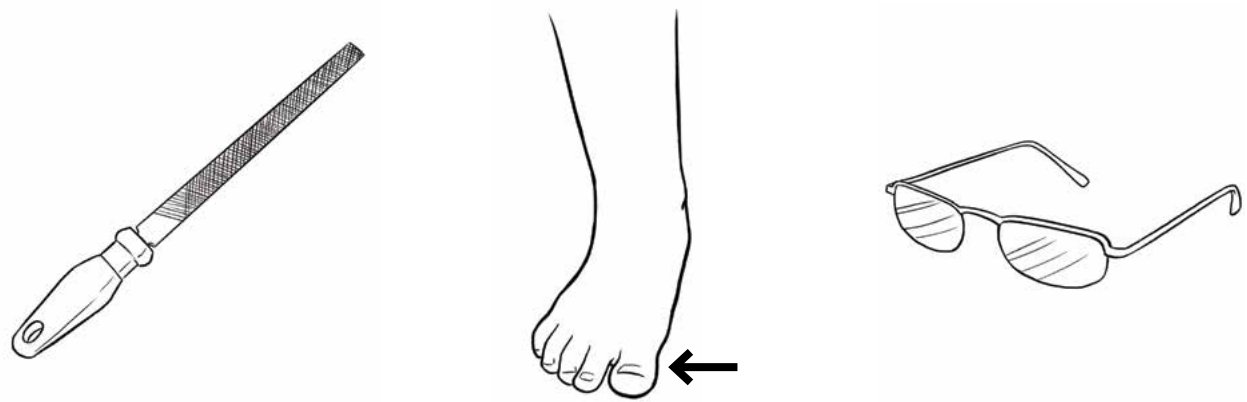

Handwriting practice for the letter 'p' on a three-line grid. The first row shows a solid 'p' with a downward arrow and a curved arrow, followed by a dashed 'p' for tracing, and then five dots for independent practice.

Handwriting practice for the letter 'j' on a three-line grid. The first row shows a solid 'j' with a downward arrow and a curved arrow, followed by a dashed 'j' for tracing, and then five dots for independent practice.

Handwriting practice for the letter 'l' on a three-line grid. The first row shows a solid 'l' with a downward arrow and a curved arrow, followed by a dashed 'l' for tracing, and then five dots for independent practice.

Handwriting practice for the letter 'p' on a three-line grid. The first row shows a solid 'p' with a dot, followed by four dashed 'p's for tracing, and then five dots for independent practice.

Handwriting practice for the letter 'j' on a three-line grid. The first row shows a solid 'j' with a dot, followed by four dashed 'j's for tracing, and then five dots for independent practice.

Handwriting practice for the letter 'l' on a three-line grid. The first row shows a solid 'l' with a dot, followed by four dashed 'l's for tracing, and then five dots for independent practice.

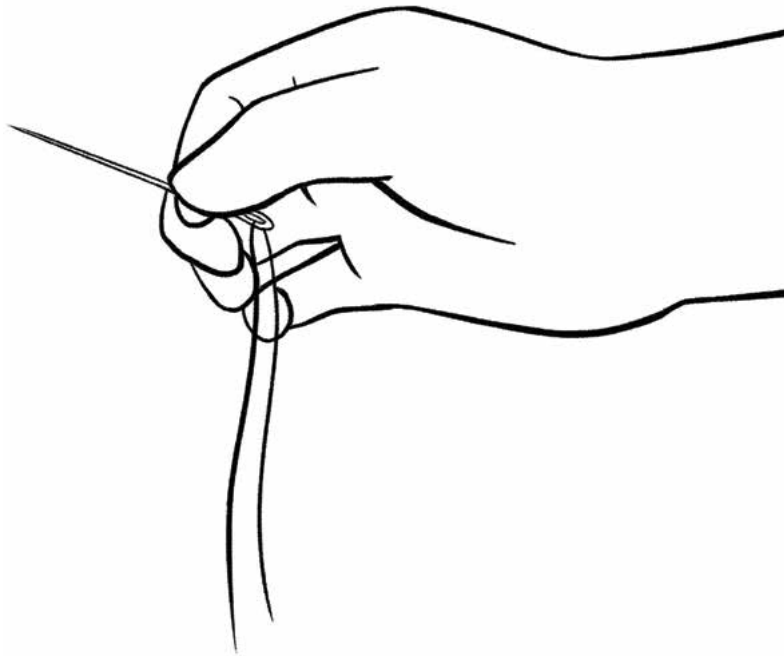
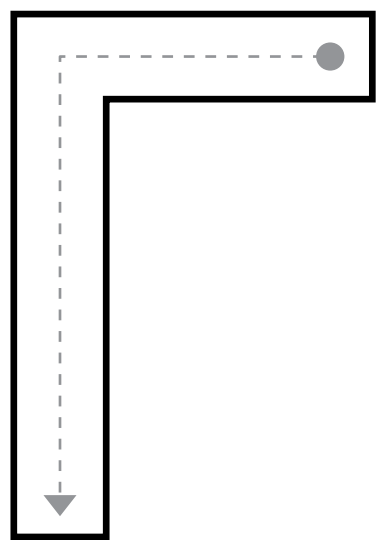

Handwriting practice for the letter 'r' on a three-line grid. The first row shows a solid 'r' with a downward arrow and a rightward arrow, followed by four dashed 'r's for tracing, and then five dots for independent practice.

Handwriting practice for the letter 'p' on a three-line grid. The first row shows a solid 'p' with a dot, followed by four dashed 'p's for tracing, and then five dots for independent practice.

Handwriting practice for the letter 'j' on a three-line grid. The first row shows a solid 'j' with a dot, followed by four dashed 'j's for tracing, and then five dots for independent practice.

Handwriting practice for the letter 'l' on a three-line grid. The first row shows a solid 'l' with a dot, followed by four dashed 'l's for tracing, and then five dots for independent practice.

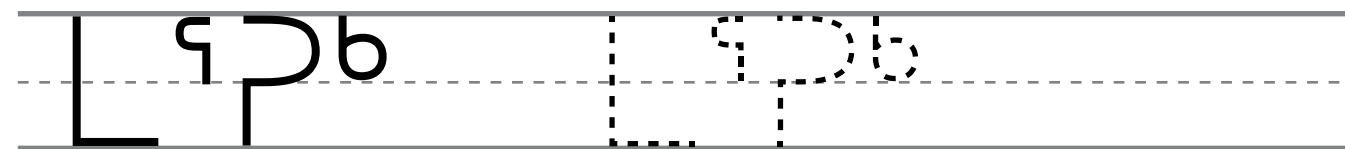
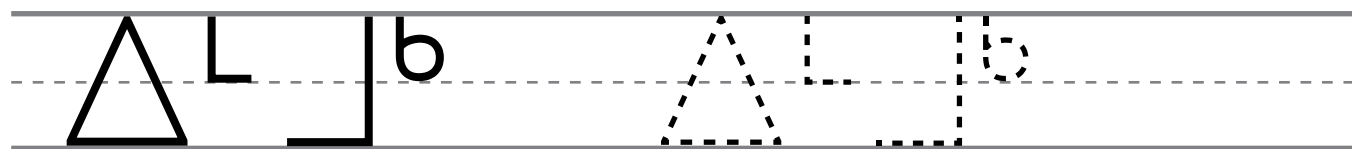
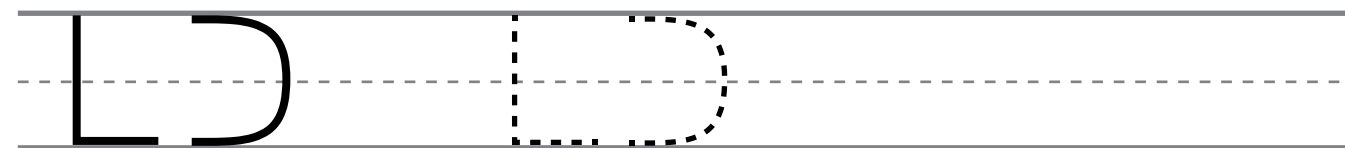
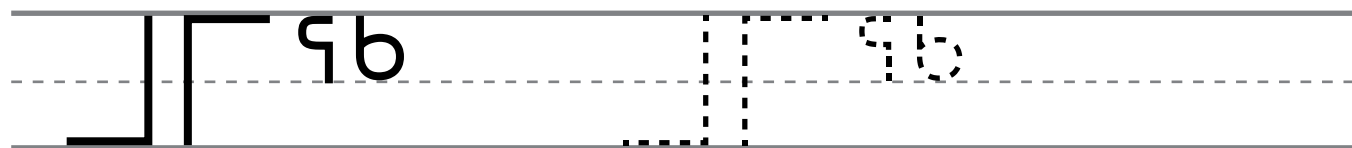
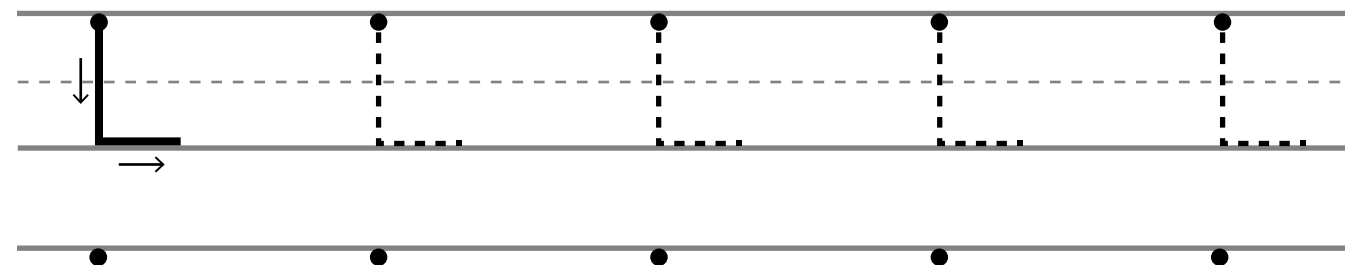
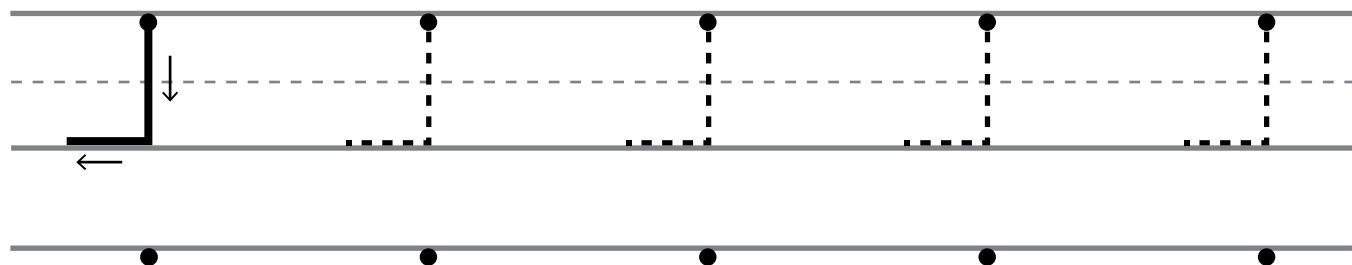
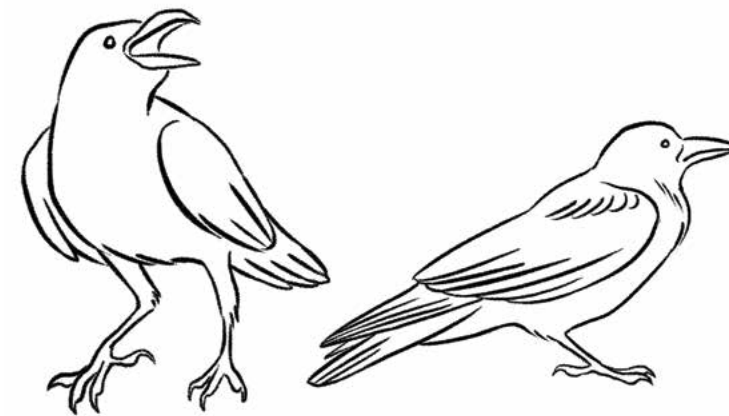
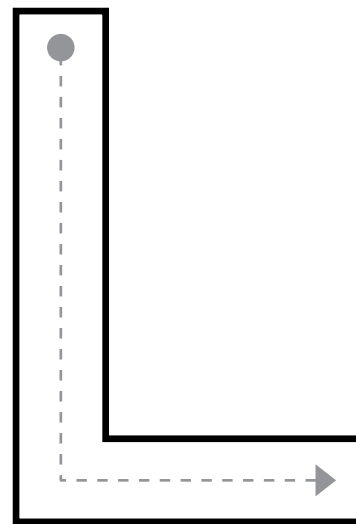
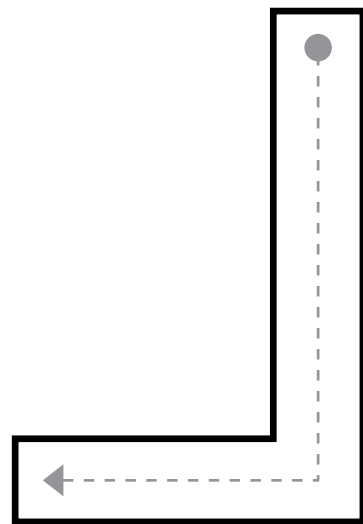



Handwriting practice for the letter 'L' on a four-line grid. The first row shows a solid 'L' with arrows indicating stroke direction (down, then left) and a dashed 'L' for tracing. The second row shows a solid 'L' with arrows and a dashed 'L'. The third row shows a solid 'L' with arrows and a dashed 'L'. The fourth, fifth, and sixth rows each show a solid 'L' followed by four dotted 'L's for tracing, each with a starting dot on the top line.

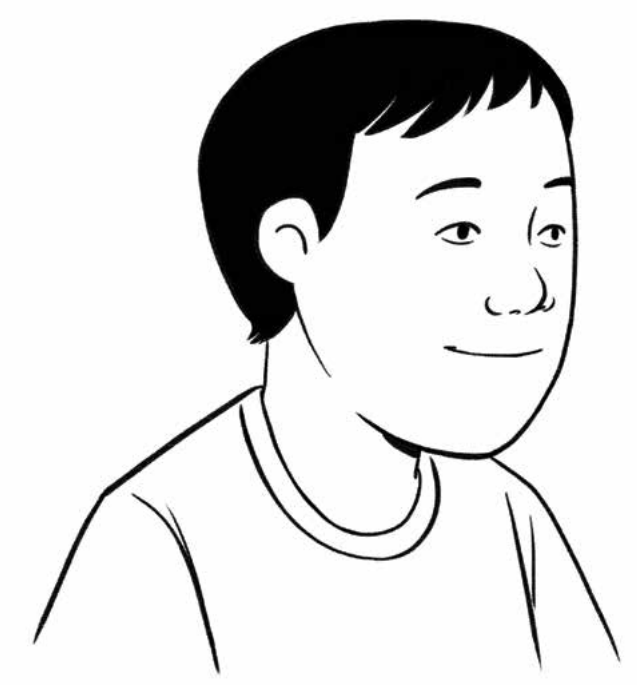
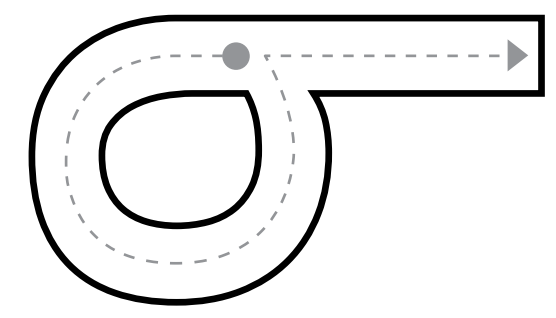

Handwriting practice for the letter 'Q' on a four-line grid. The first row shows a solid 'Q' with arrows indicating stroke direction (counter-clockwise circle, then horizontal tail) and four dotted 'Q's for tracing. The second row shows five starting dots on the top line. The third row shows a solid 'Q' followed by a dotted 'Q' with arrows and numbers '1' and '2' indicating stroke order, followed by two more dotted 'Q's with arrows and numbers. The fourth row shows a solid 'Q' followed by a dotted 'Q' with arrows and numbers, followed by two more dotted 'Q's with arrows and numbers.

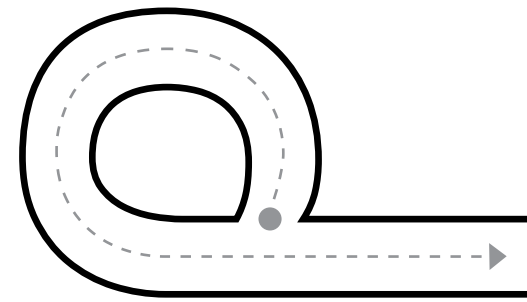
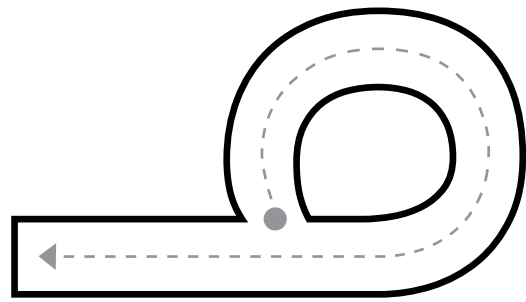

Handwriting practice for the letter 'o' on page 26. The page contains four rows of handwriting lines (top, middle dashed, bottom).
 Row 1: A solid lowercase 'o' with stroke direction arrows, followed by four dashed lowercase 'o's for tracing.
 Row 2: Five dots on the bottom line, serving as starting points for writing.
 Row 3: A solid lowercase 'o' with a lightning bolt symbol and the letter 'c', followed by a dashed version of the same for tracing.
 Row 4: A solid lowercase 'o' with a lightning bolt symbol, a letter 'c', and a number '6', followed by a dashed version of the same for tracing.

Handwriting practice for the letter 'o' on page 27. The page contains four rows of handwriting lines (top, middle dashed, bottom).
 Row 1: A solid lowercase 'o' with stroke direction arrows, followed by four dashed lowercase 'o's for tracing.
 Row 2: Five dots on the bottom line, serving as starting points for writing.
 Row 3: A solid lowercase 'o' with a lightning bolt symbol and the letter 'b', followed by a dashed version of the same for tracing.
 Row 4: A solid lowercase 'o' with a lightning bolt symbol, a letter 'b', and a triangle, followed by a dashed version of the same for tracing.



Handwriting practice for the letter 'o'. The first row shows a solid 'o' with a counter-clockwise arrow, followed by a dashed 'o' for tracing, and four dots on a dashed line for independent practice. The second row shows a solid 'o' with arrows indicating the stroke direction, followed by a dashed 'o' for tracing, and four dots on a dashed line. The third row shows a solid 'o' with arrows, followed by a dashed 'o' for tracing, and four dots on a dashed line. The fourth row shows a solid 'o' followed by four dots on a dashed line. The fifth row shows a solid 'o' followed by four dots on a dashed line. The sixth row shows a solid 'o' followed by four dots on a dashed line.

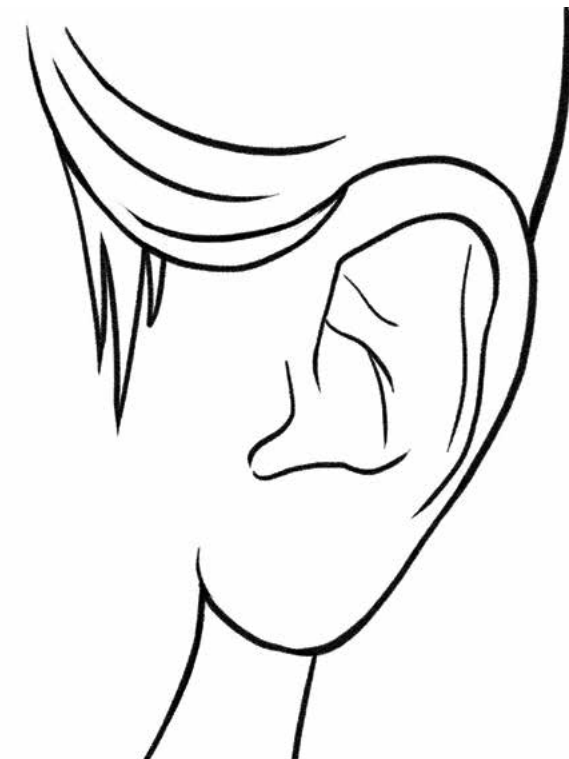
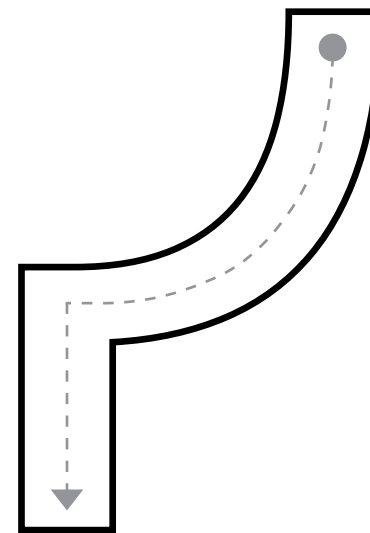

Handwriting practice for the letter 'r'. The first row shows a solid 'r' with arrows, followed by four dashed 'r's for tracing, and five dots on a dashed line. The second row shows five dots on a dashed line. The third row shows a solid 'r' followed by a solid 'b', followed by a dashed 'r' followed by a dashed 'b' for tracing, and four dots on a dashed line. The fourth row shows a solid 'r' followed by a solid 'b', followed by a dashed 'r' followed by a dashed 'b' for tracing, and four dots on a dashed line. The fifth row shows a solid 'r' followed by a solid 'b', followed by a dashed 'r' followed by a dashed 'b' for tracing, and four dots on a dashed line.

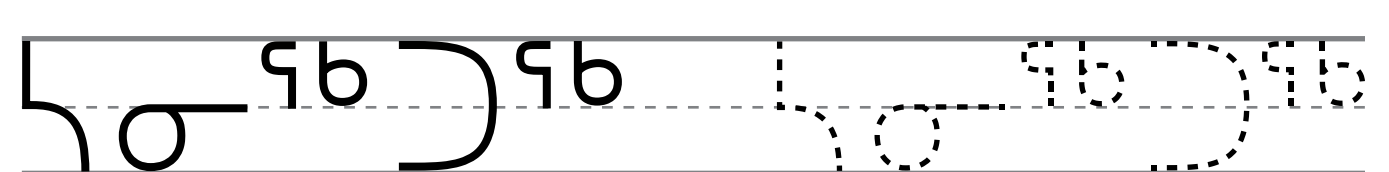
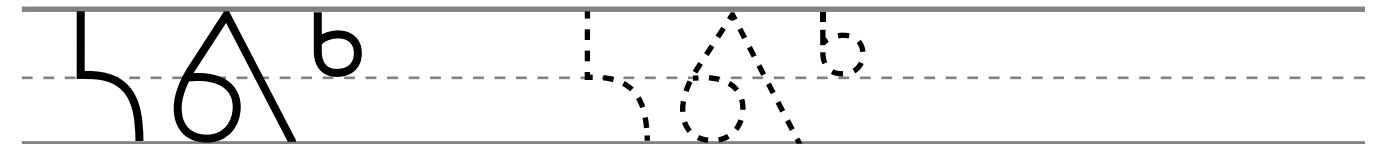
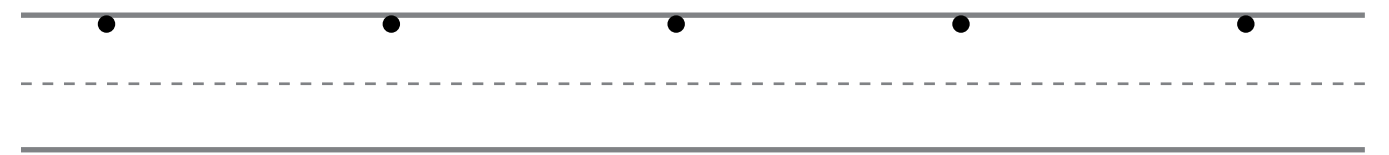
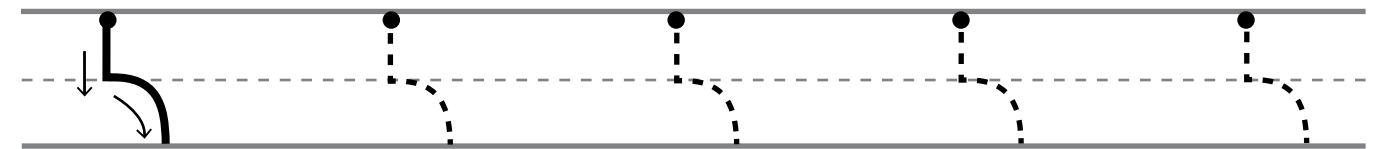
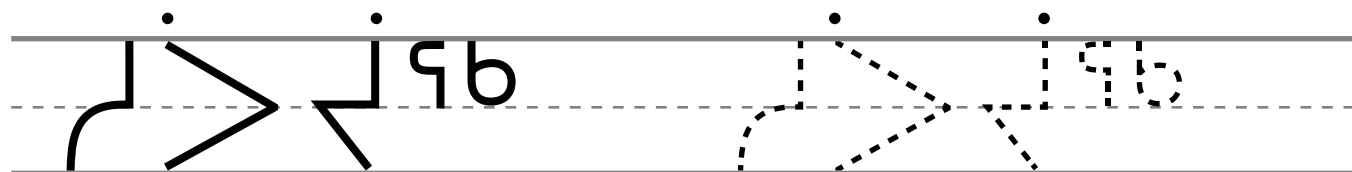
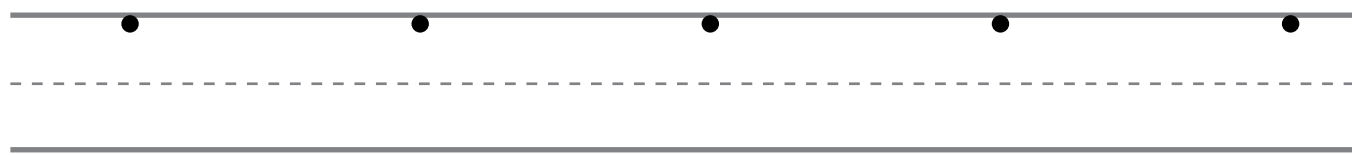
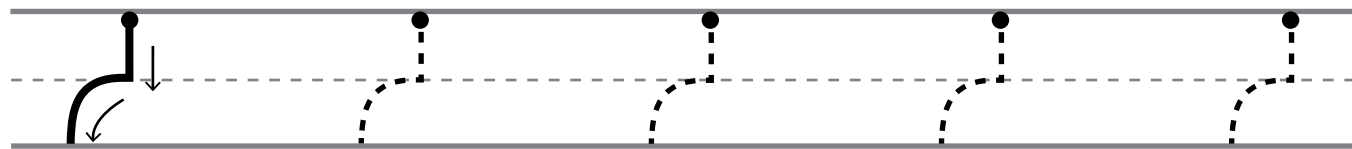
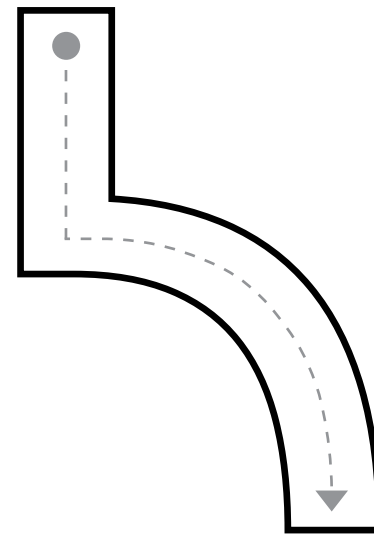
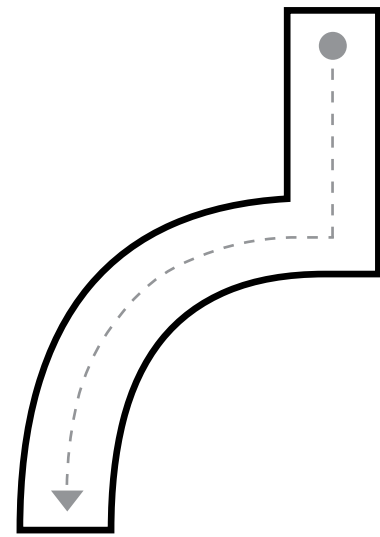
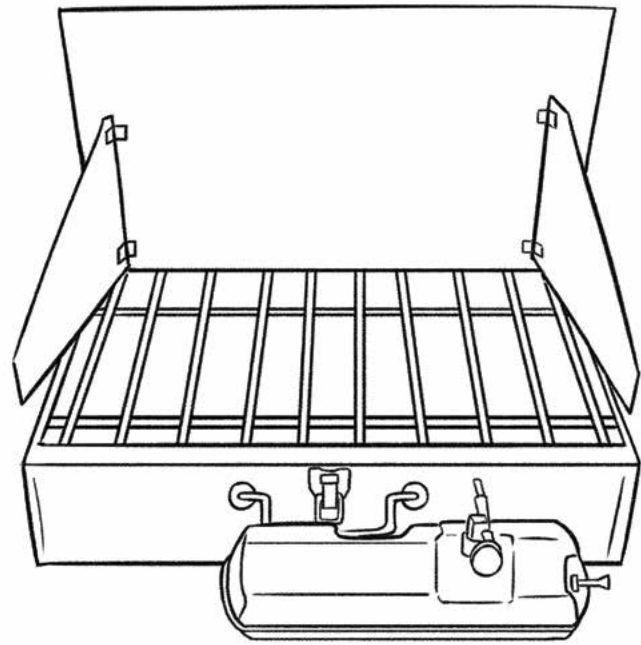

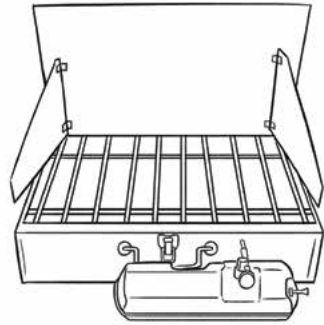

Handwriting practice lines for the letter 'C'. Each line consists of a top solid line, a middle dashed line, and a bottom solid line. The first line shows a solid 'C' with a starting dot and a downward arrow, followed by a dashed 'C' for tracing. The next two lines show a solid 'C' with a starting dot and a downward arrow, followed by a dashed 'C' for tracing. The remaining three lines show a solid 'C' with a starting dot, followed by a dashed 'C' for tracing. The final line shows a solid 'C' with a starting dot.

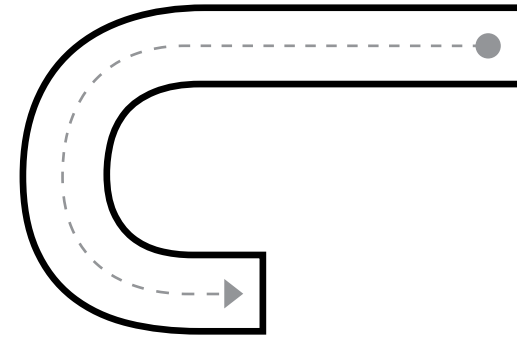

Handwriting practice lines for the letter 'C'. The first line shows a solid 'C' with a starting dot and a leftward arrow, followed by four dashed 'C's for tracing. The second line shows five starting dots on the dashed line. The third line shows a solid 'C' with a starting dot and a leftward arrow, followed by a dashed 'C' for tracing. The fourth line shows a solid 'C' with a starting dot and a leftward arrow, followed by a dashed 'C' for tracing. The fifth line shows a solid 'C' with a starting dot and a leftward arrow, followed by a dashed 'C' for tracing.

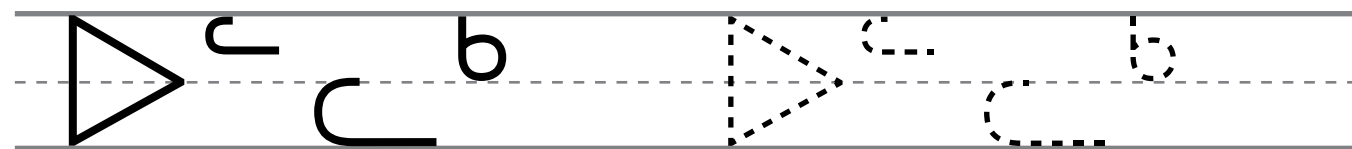
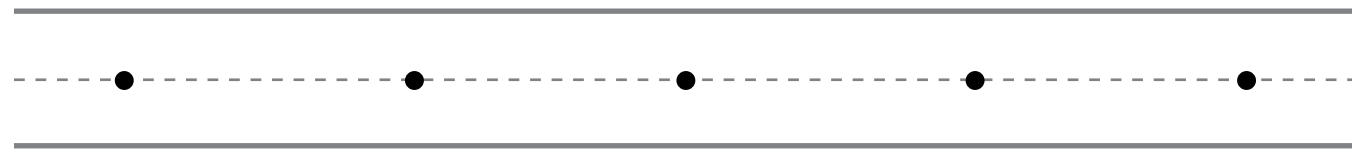
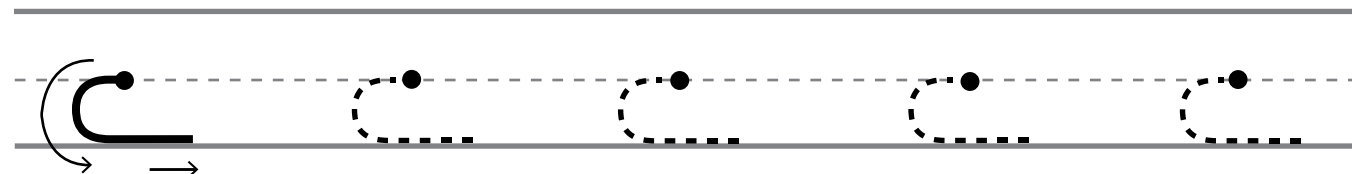
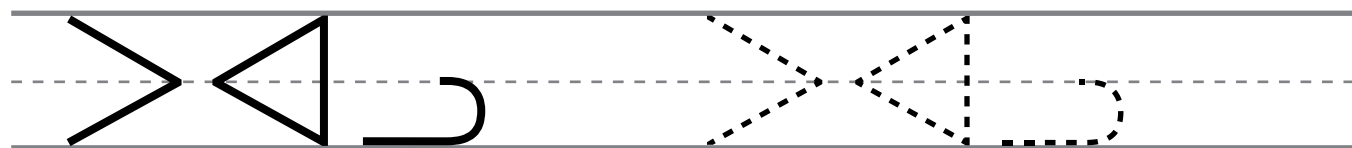
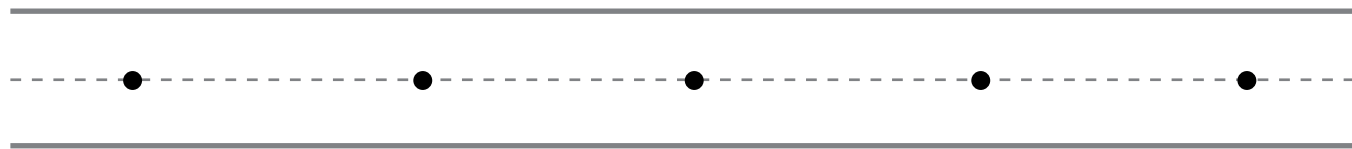
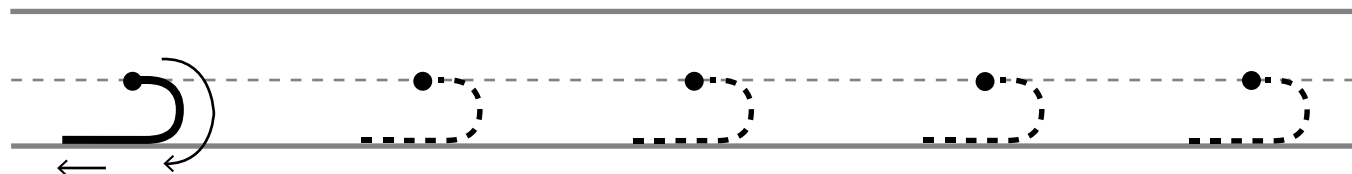
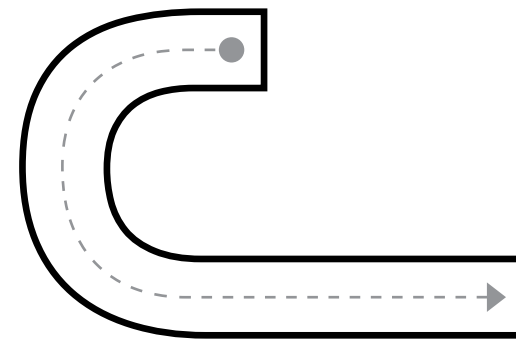
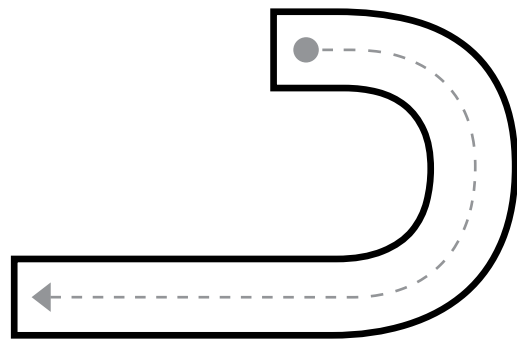
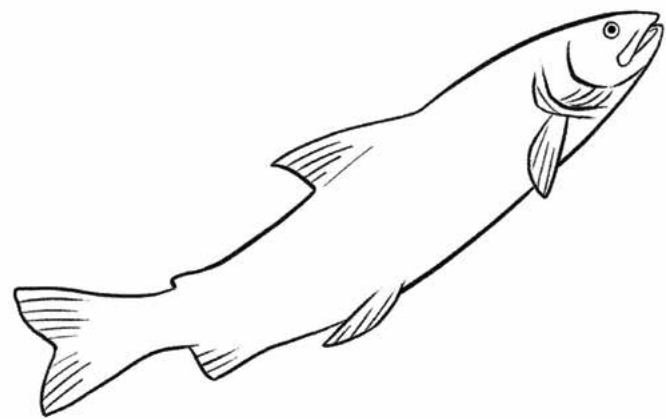

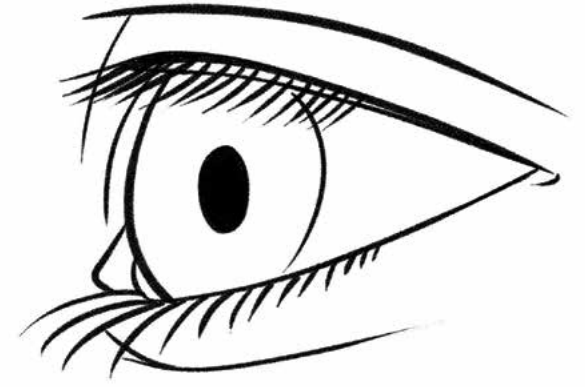
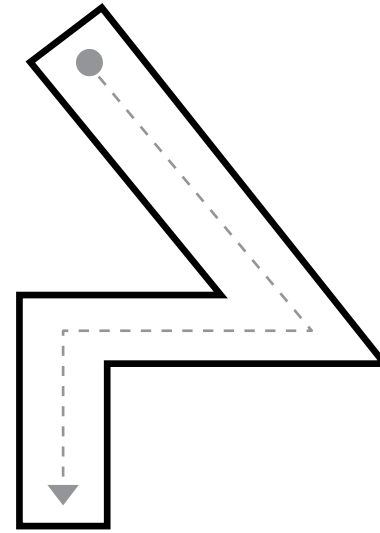
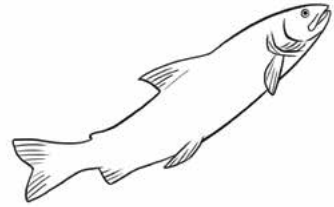

Handwriting practice for the letter 'U' on a three-line grid. The first row shows a solid 'U' with stroke direction arrows and a dashed 'U' for tracing. The second row shows a solid 'U' with stroke direction arrows and a dashed 'U' for tracing. The third row shows a solid 'U' with stroke direction arrows and a dashed 'U' for tracing. The fourth row shows a solid 'U' followed by four dots on the dashed line. The fifth row shows a solid 'U' followed by four dots on the dashed line. The sixth row shows a solid 'U' followed by four dots on the dashed line.

Handwriting practice for the letter 'A' on a three-line grid. The first row shows a solid 'A' with stroke direction arrows and four dashed 'A's for tracing. The second row shows five dots on the dashed line. The third row shows a solid 'A' with stroke direction arrows and a dashed 'A' for tracing. The fourth row shows a solid 'A' with stroke direction arrows and a dashed 'A' for tracing.

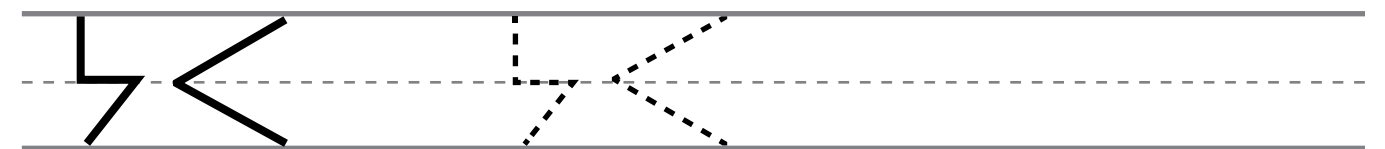
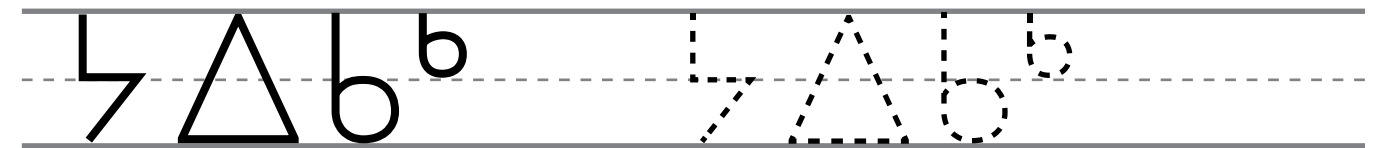
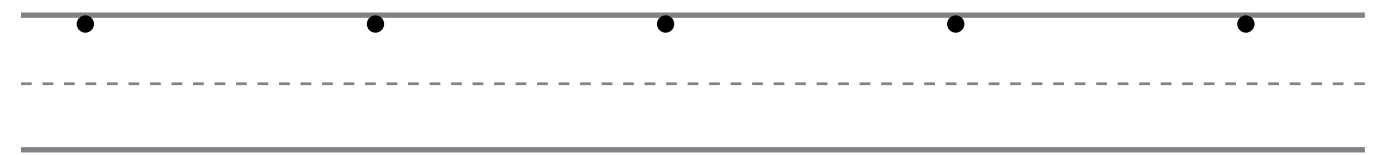
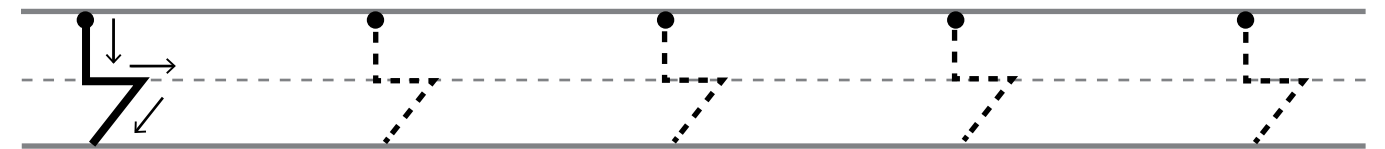
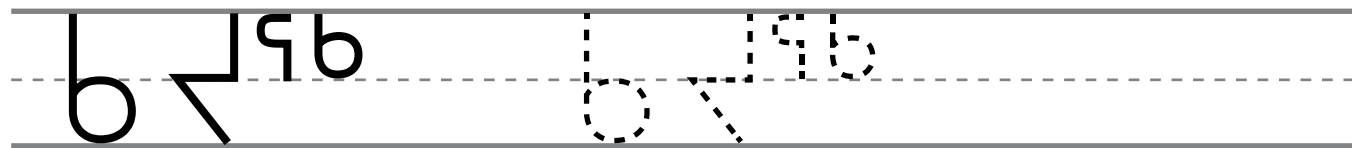
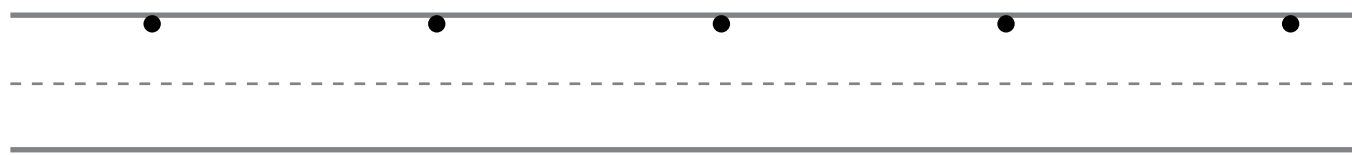
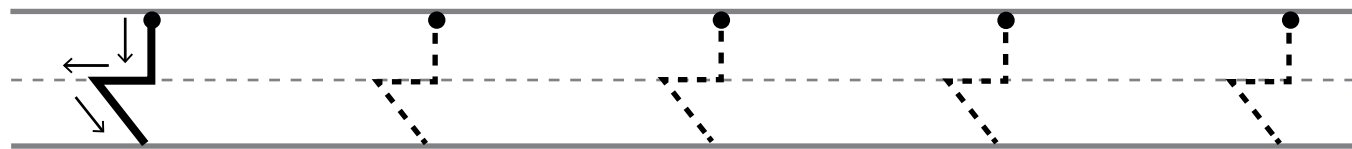
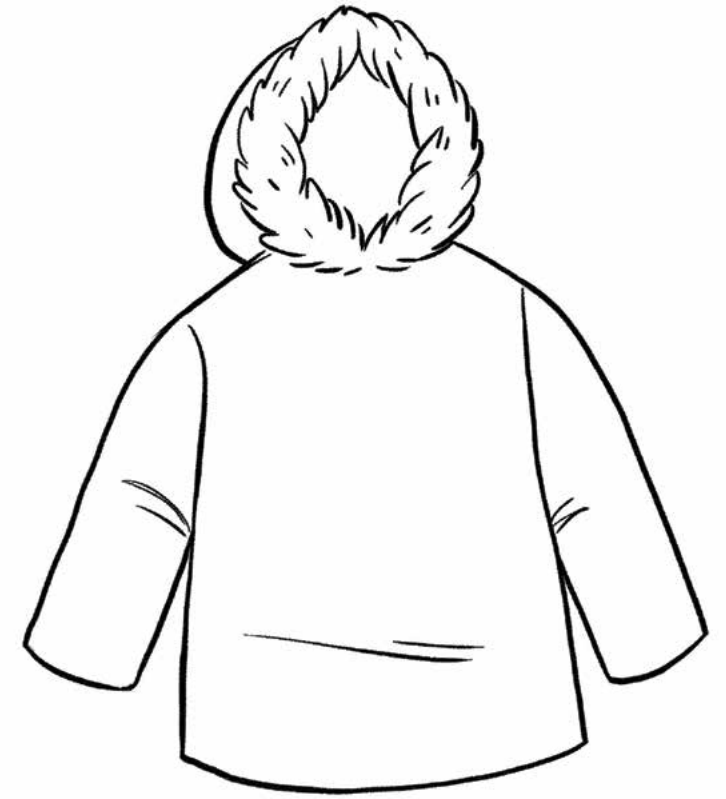
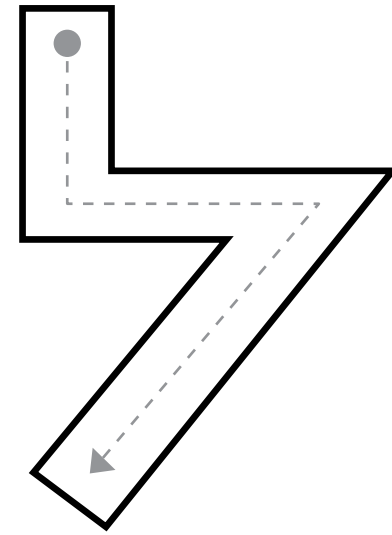
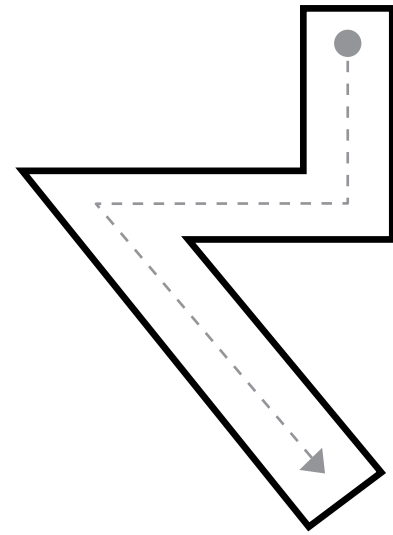
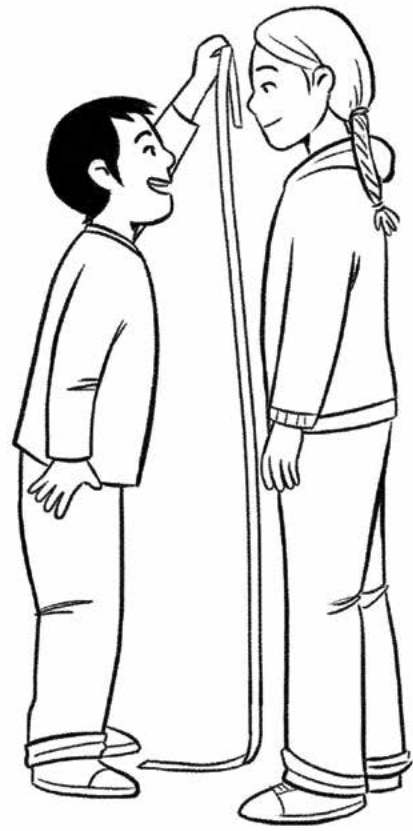

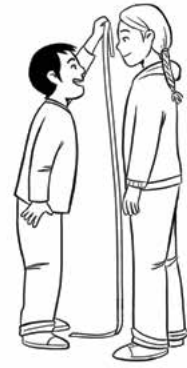

Handwriting practice lines for the Inuktitut syllable 'a' (ᐅ). The page contains six rows of three-line guides (top, middle dashed, bottom). Each row starts with a solid 'a' showing stroke order: a vertical line down, a horizontal line to the right, and a diagonal line down to the right. This is followed by a dashed 'a' for tracing, and then four dots on the top line for independent practice.

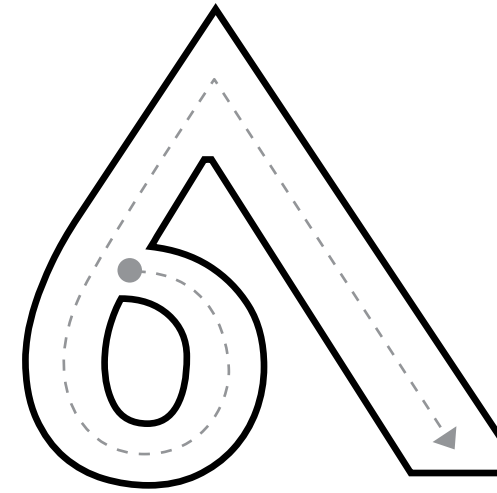

Handwriting practice lines for the Inuktitut syllable 'a' (ᐅ). The page contains three rows of three-line guides. The first row starts with a solid 'a' showing stroke order: a counter-clockwise circle, a vertical line down, and a diagonal line down to the right. This is followed by four dashed 'a's for tracing, and then five dots on the top line for independent practice. The second row contains a solid 'a' followed by a dashed 'a' and a dot on the top line. The third row contains a solid 'a' followed by a dashed 'a' and a dot on the top line.

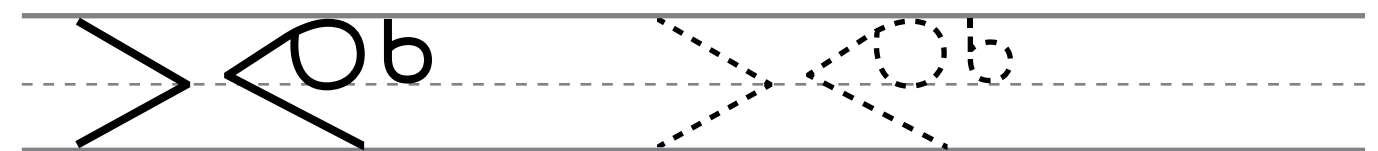
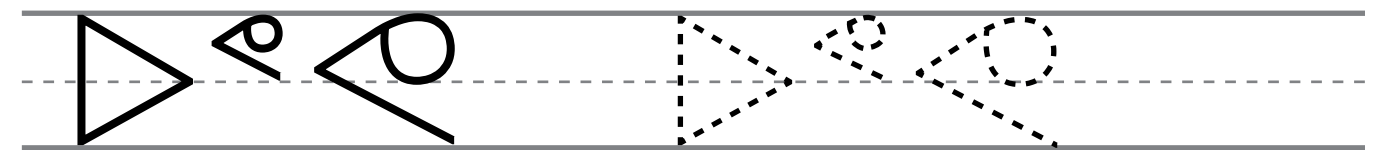
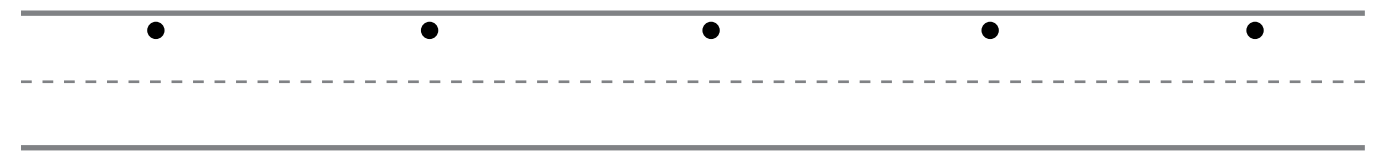
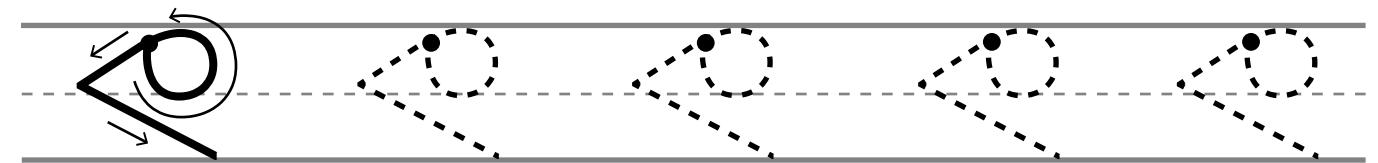
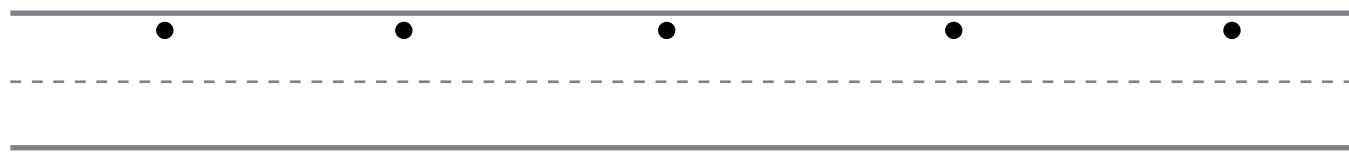
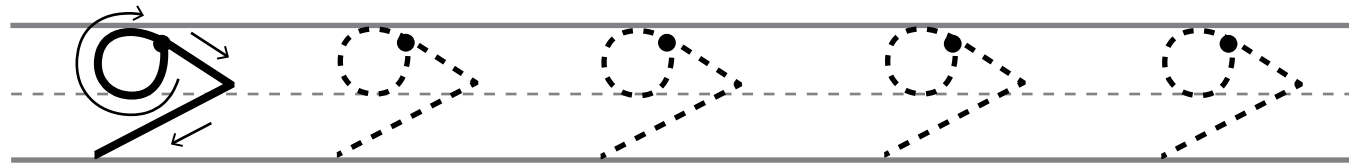
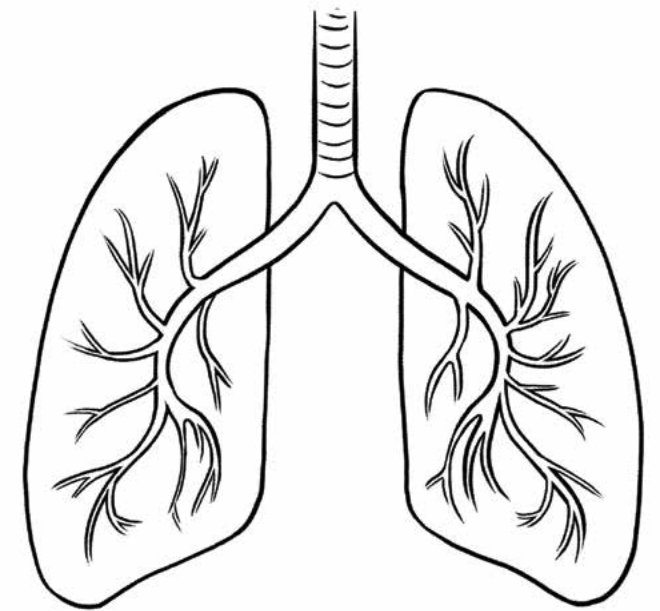
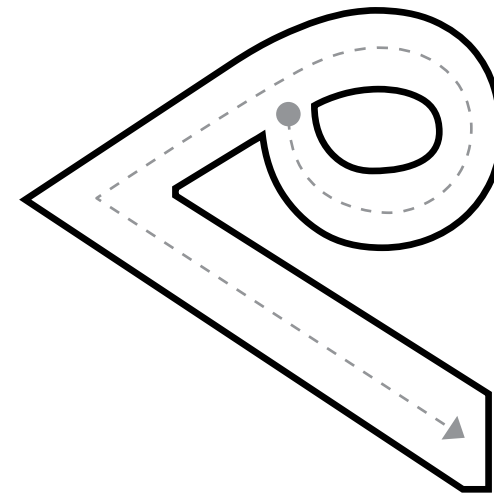
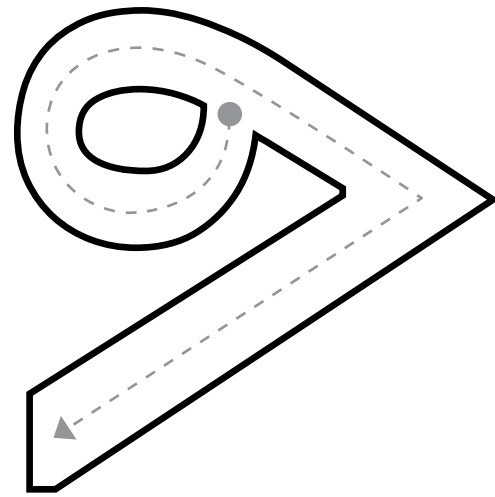
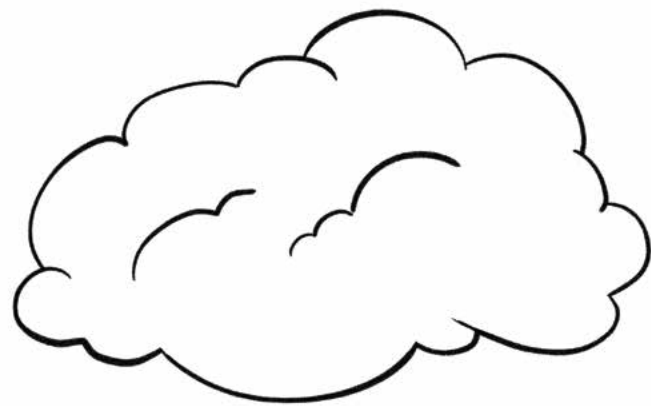

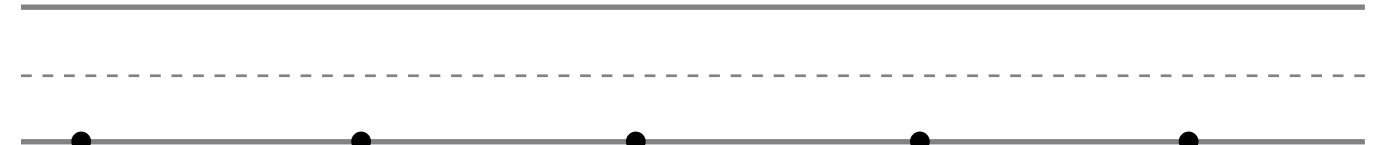
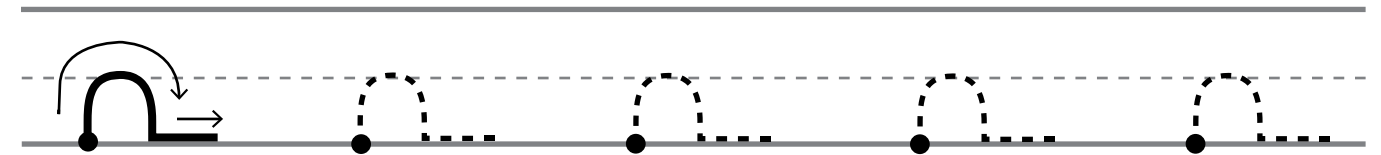
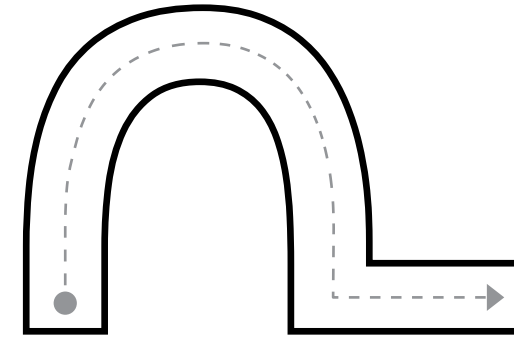
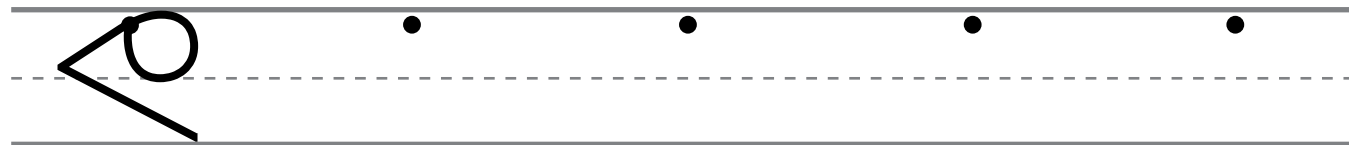
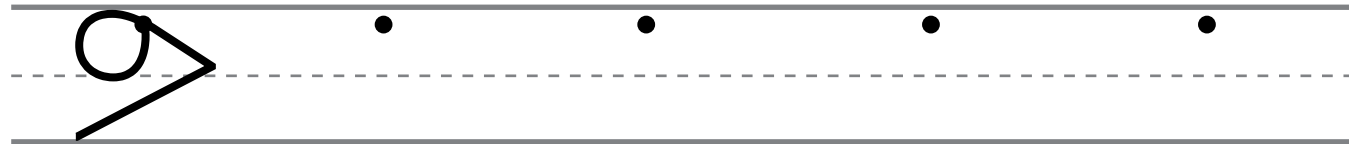
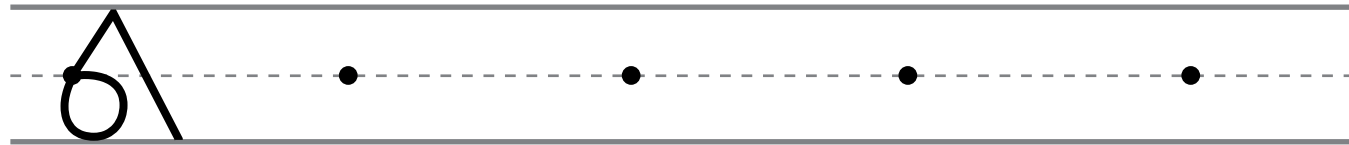
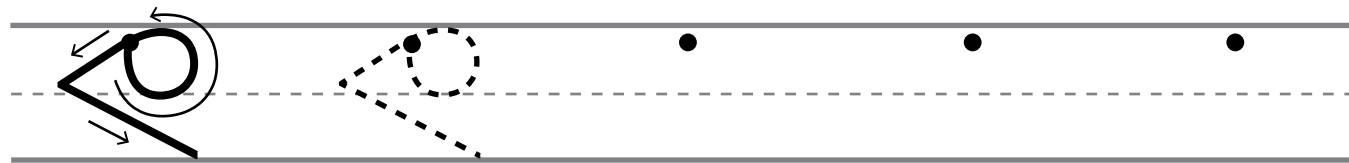
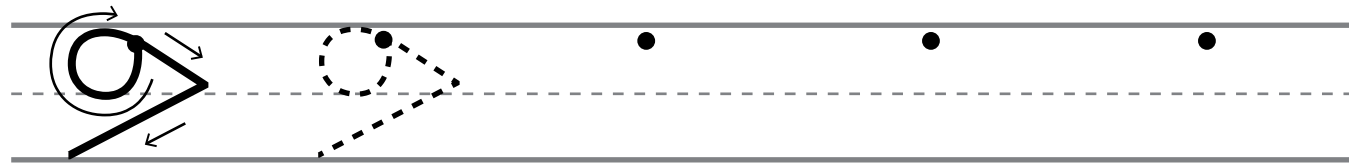
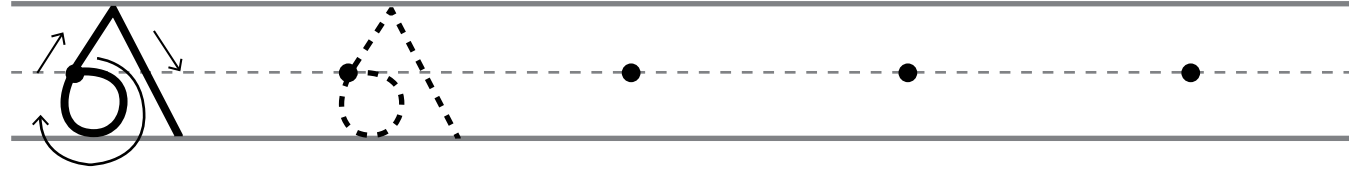
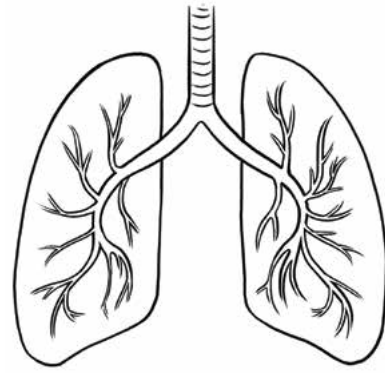

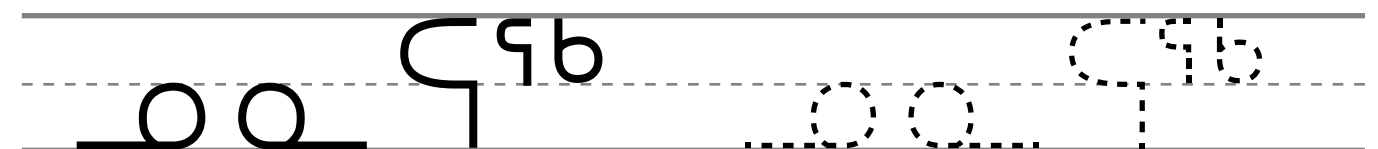
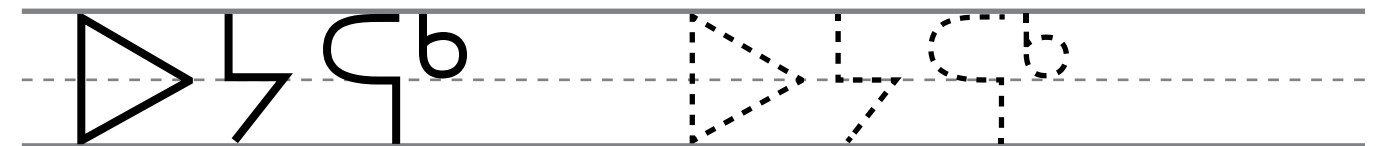
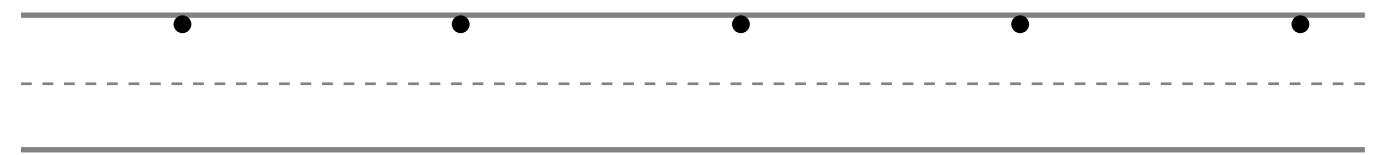
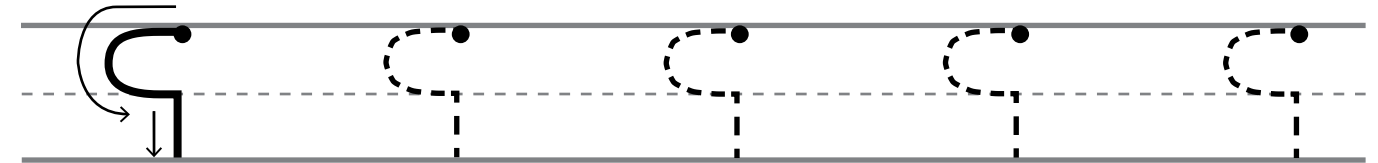
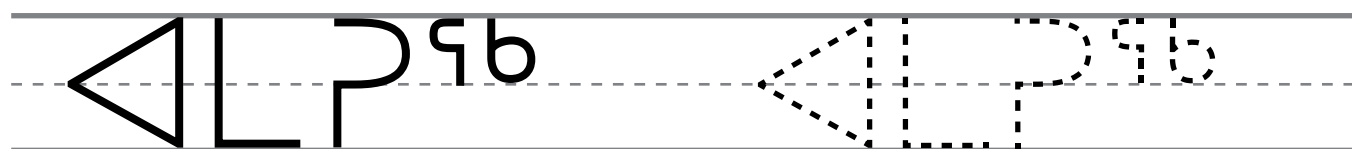
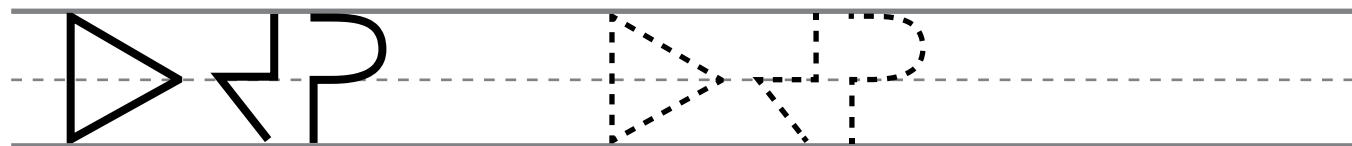
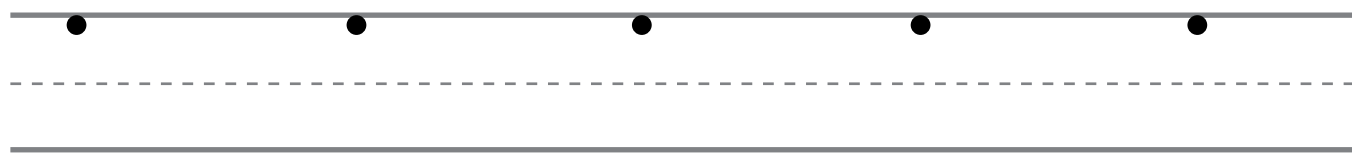
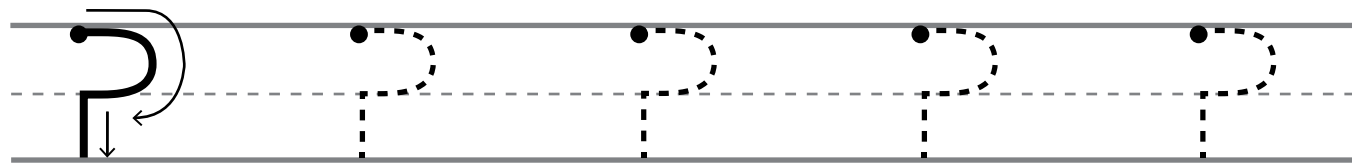
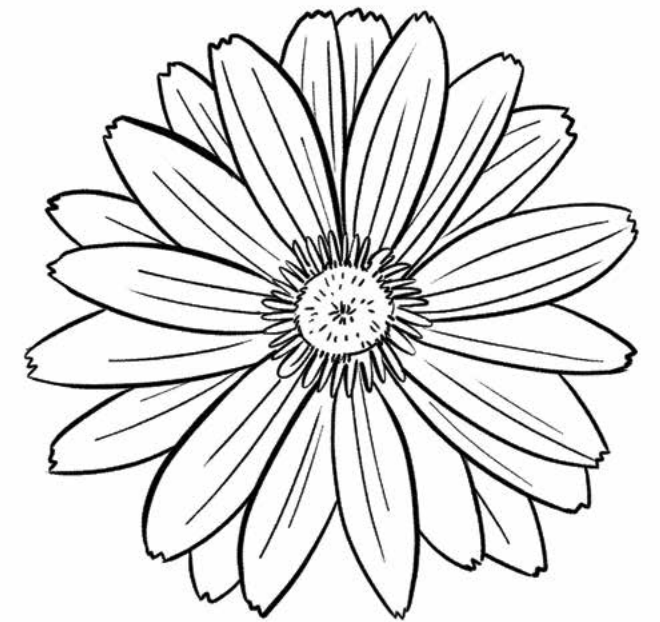
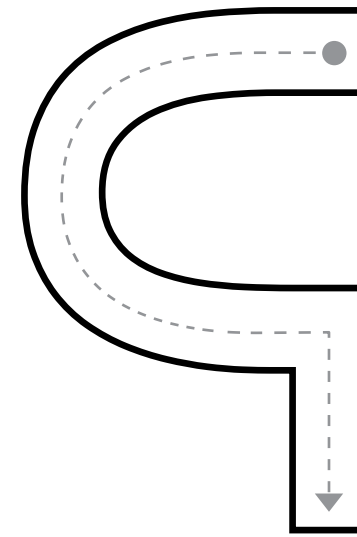
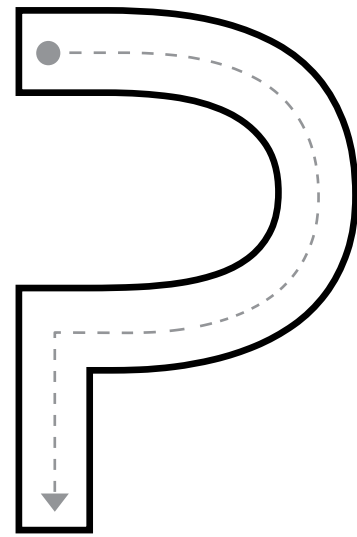
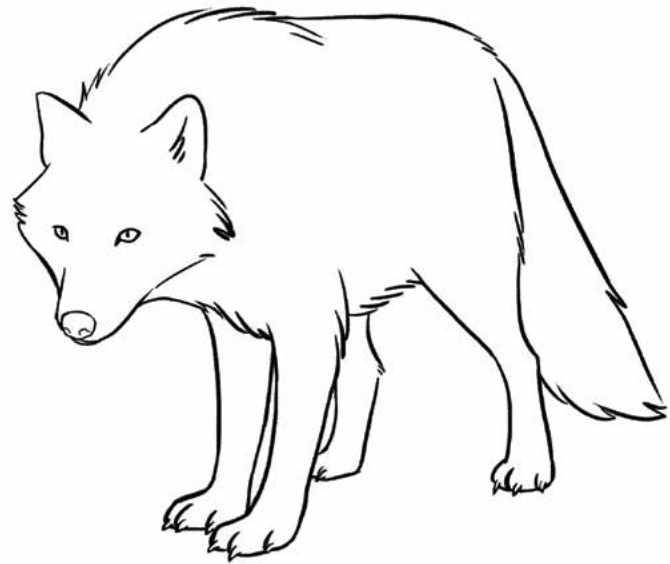

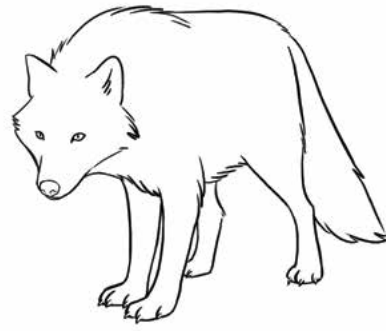

Handwriting practice lines for lowercase letters 'a', 'p', and 'q'. Each letter is shown with stroke order arrows and a starting dot. The letters are followed by dashed versions for tracing and solid versions with starting dots for independent practice.

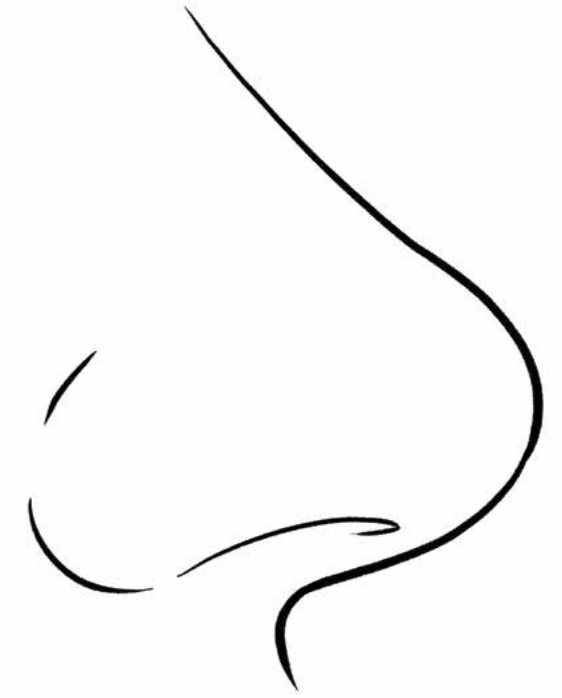
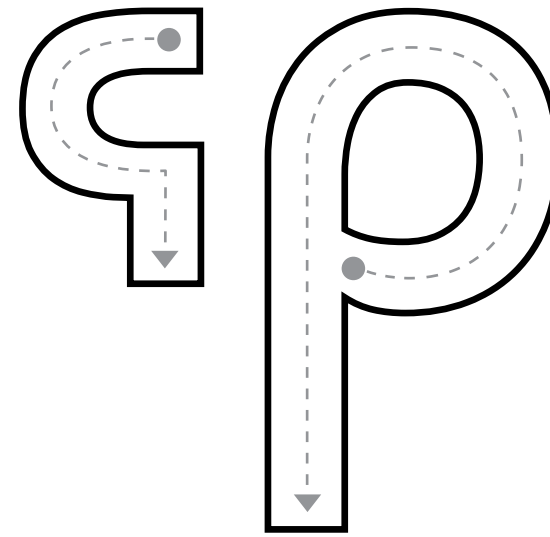

Handwriting practice lines for uppercase letters 'Q' and 'P'. The first row shows 'Q' and 'P' with stroke order arrows and starting dots, followed by dashed versions for tracing. The second row shows solid versions with starting dots. The third row shows 'Q' and 'P' with stroke order arrows and starting dots, followed by dashed versions for tracing. The fourth row shows solid versions with starting dots.

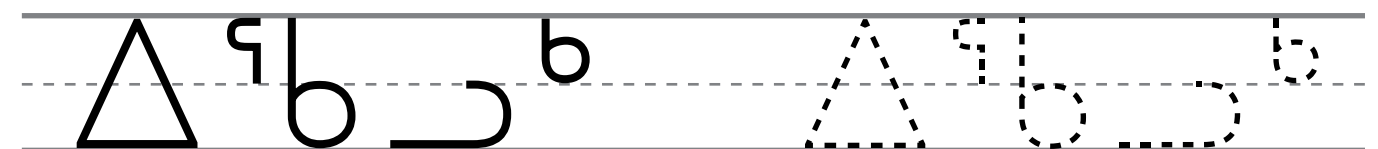
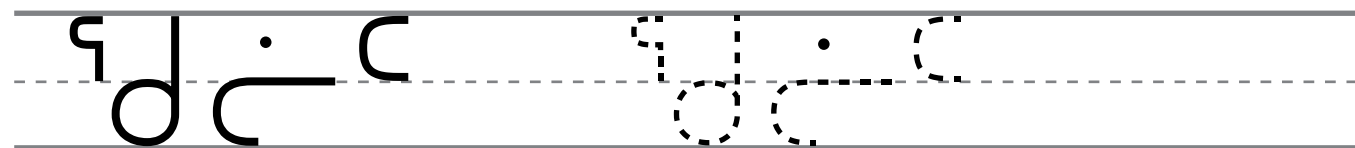
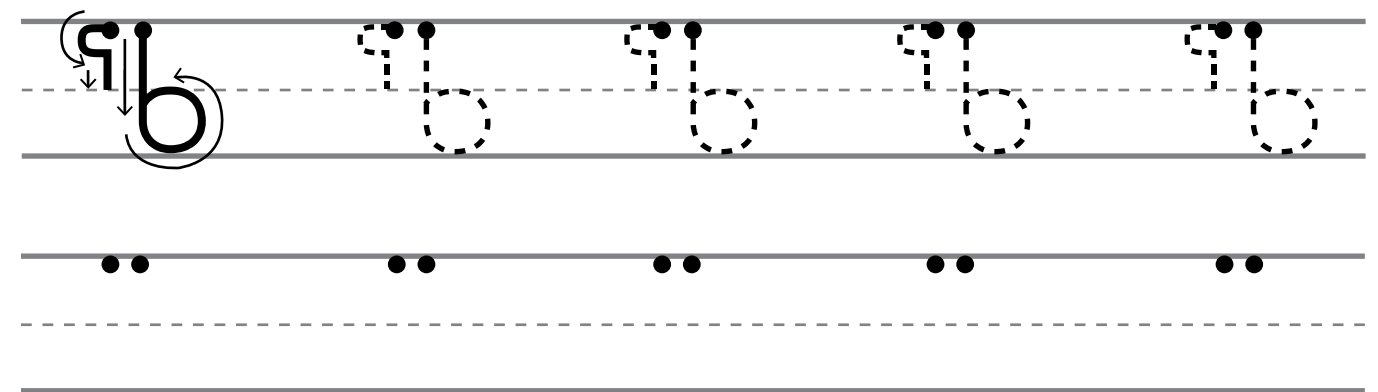
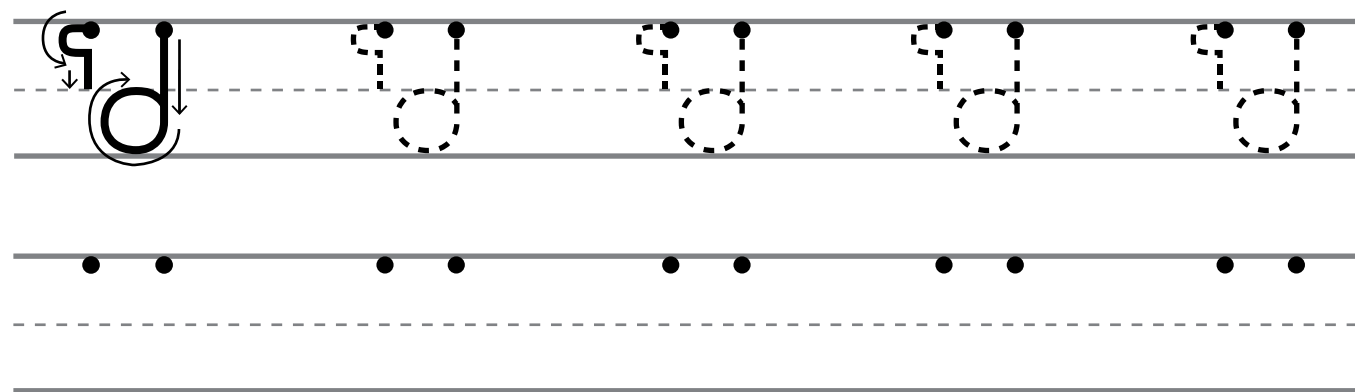
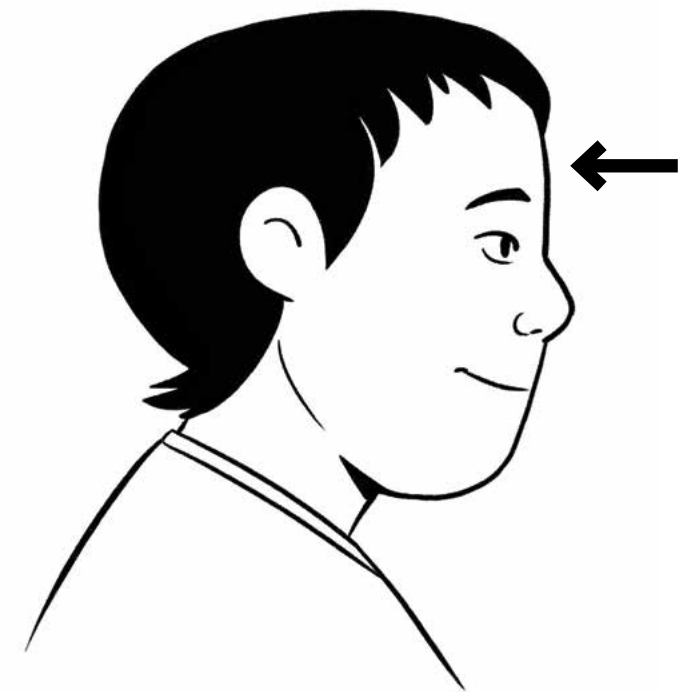
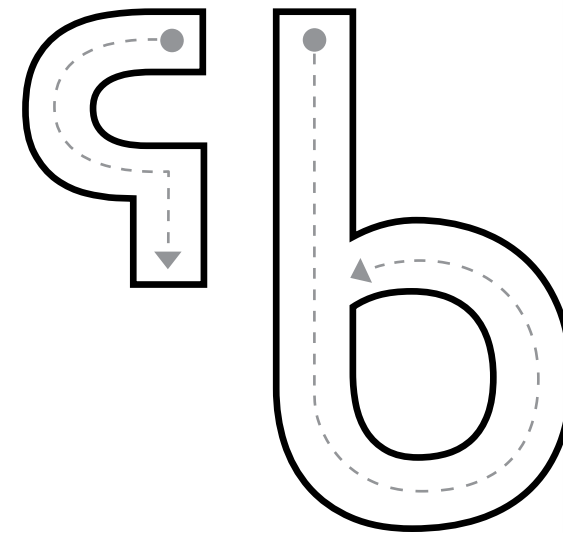
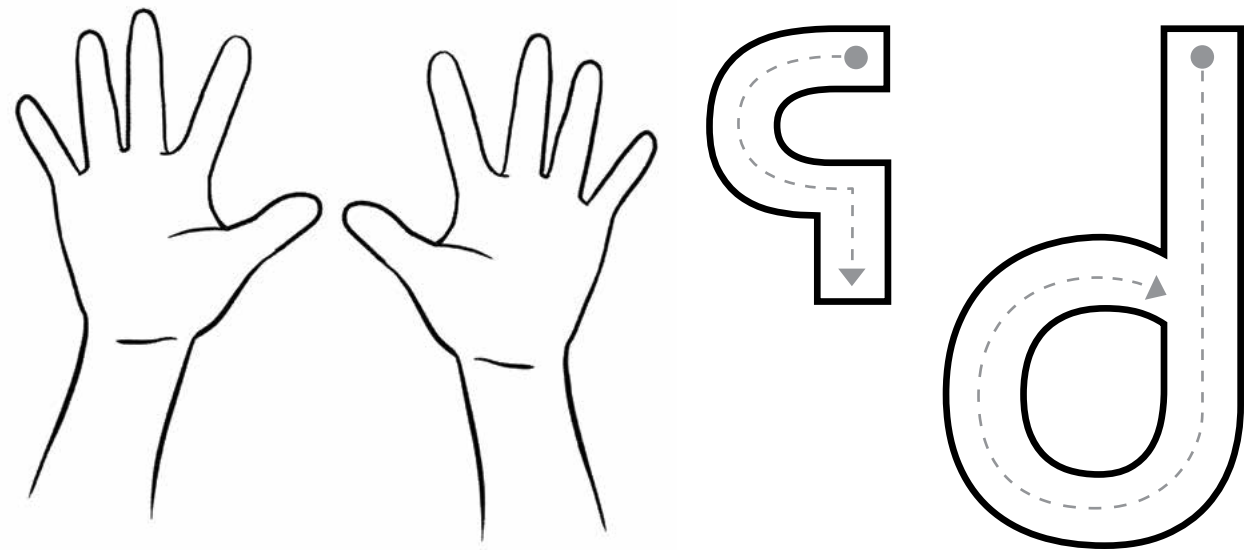

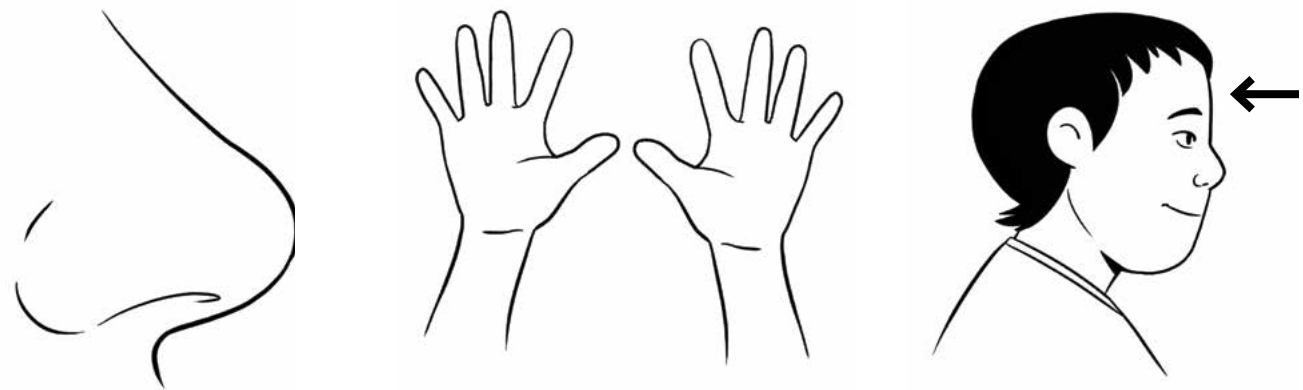

Handwriting practice for page 52. It consists of seven rows of three-line guides (top, middle dashed, bottom). Each row contains a solid letter with numbered arrows showing stroke order, followed by a dashed version of the same letter for tracing, and then several pairs of dots for independent writing practice.

- Row 1: Letter 'p'. Stroke 1 is a counter-clockwise circle starting from the top, and stroke 2 is a vertical line down from the top of the circle.
- Row 2: Letter 'd'. Stroke 1 is a counter-clockwise circle, and stroke 2 is a vertical line down from the top of the circle.
- Row 3: Letter 'b'. Stroke 1 is a counter-clockwise circle, and stroke 2 is a vertical line down from the top of the circle.
- Row 4: Letter 'p'.
- Row 5: Letter 'd'.
- Row 6: Letter 'b'.

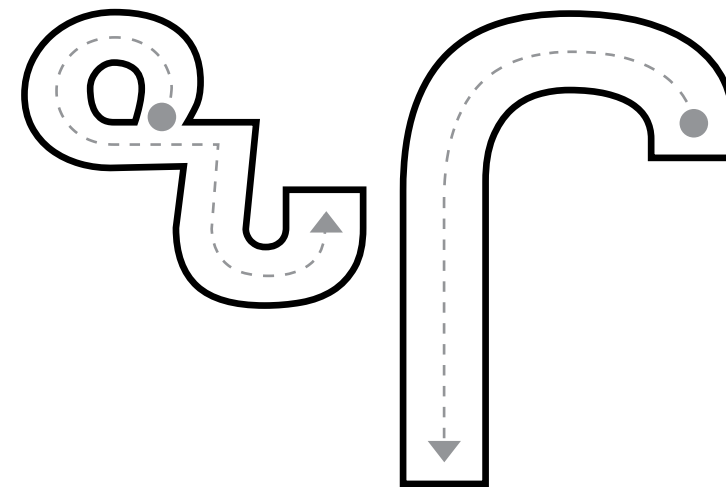

Handwriting practice for page 53. It consists of three rows of three-line guides. The first row contains a solid letter with stroke order arrows, followed by four dashed versions of the same letter for tracing. The second and third rows contain pairs of dots for independent writing practice.

- Row 1: Letter 'q'. Stroke 1 is a counter-clockwise circle, and stroke 2 is a vertical line down from the top of the circle.
- Row 2: Letter 'r'. Stroke 1 is a vertical line down, and stroke 2 is a curved line starting from the top of the vertical line, curving to the right and then down.
- Row 3: Letter 'b'. Stroke 1 is a counter-clockwise circle, and stroke 2 is a vertical line down from the top of the circle.

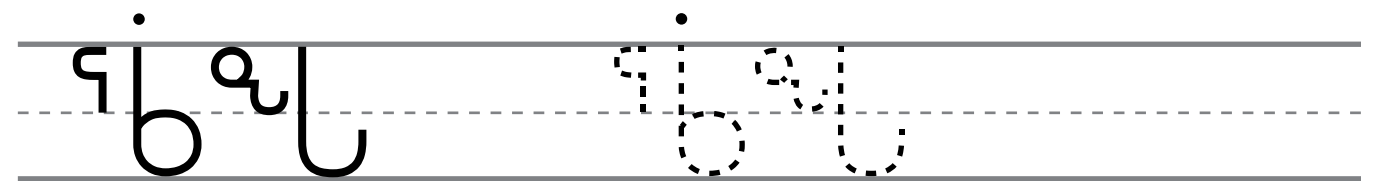
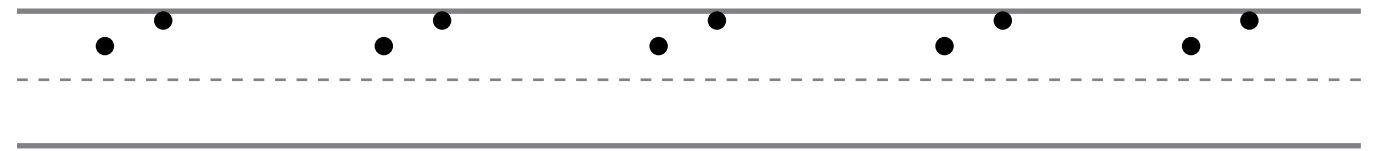
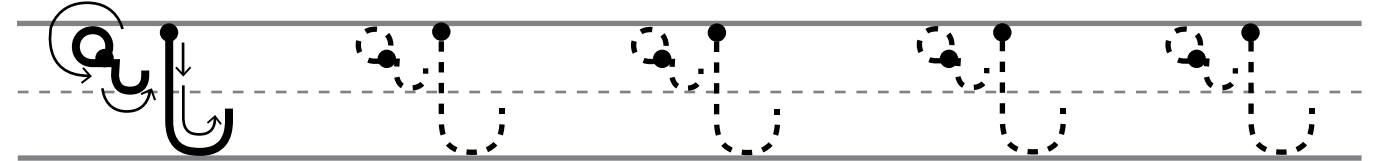
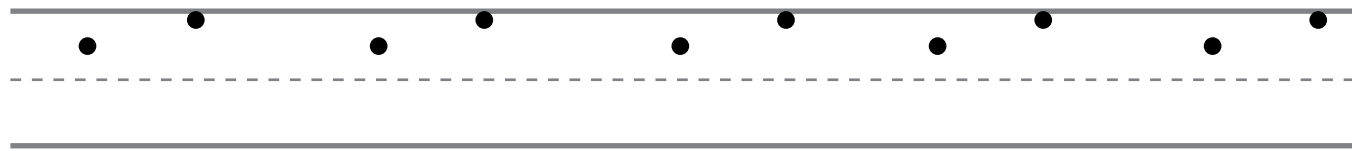
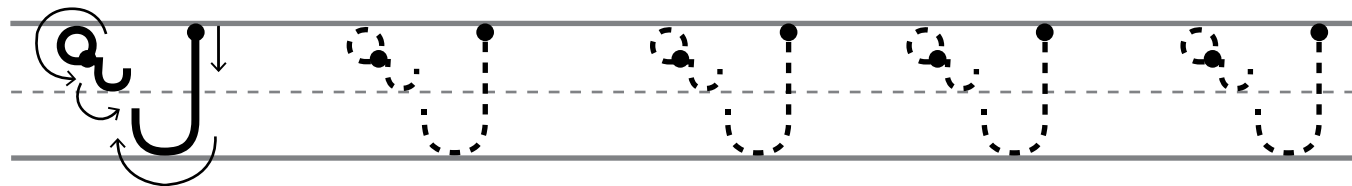
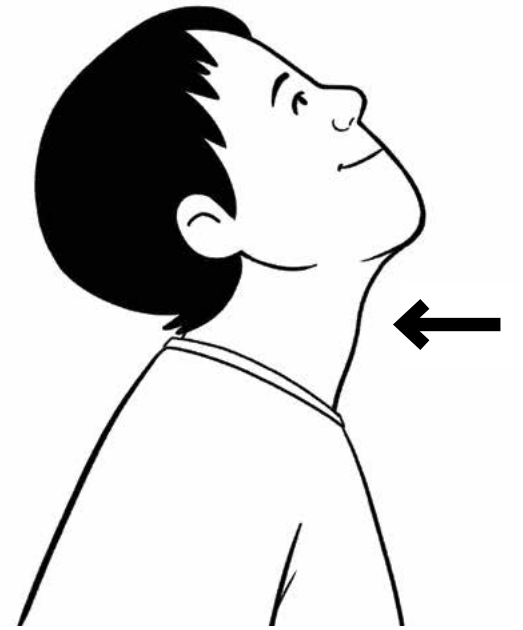
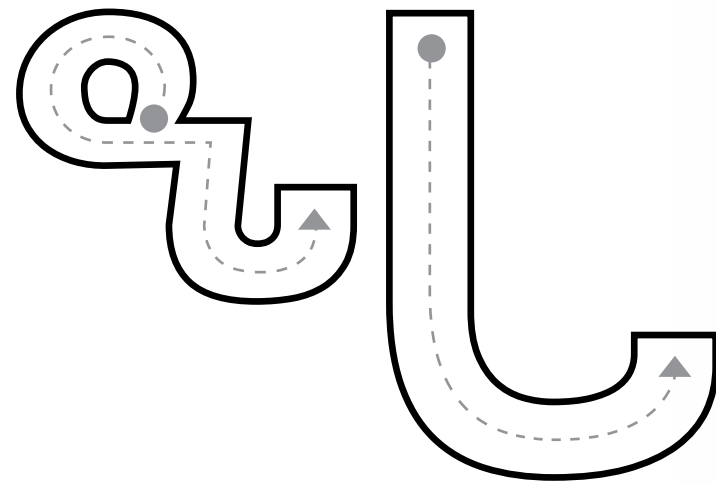
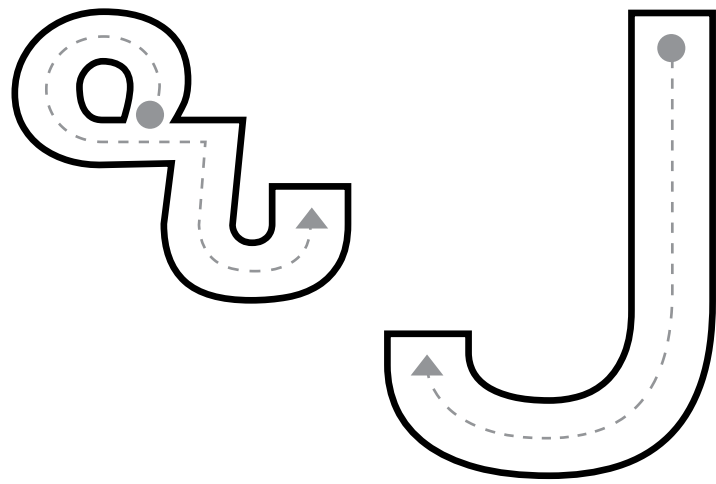
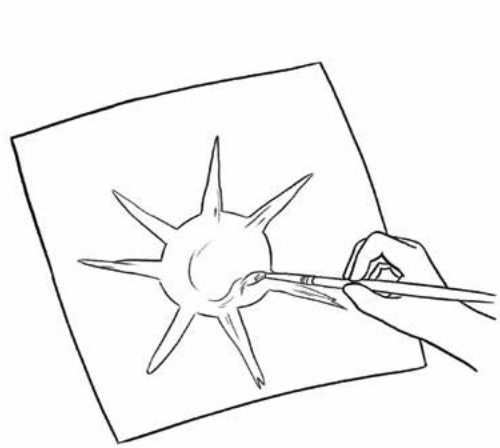

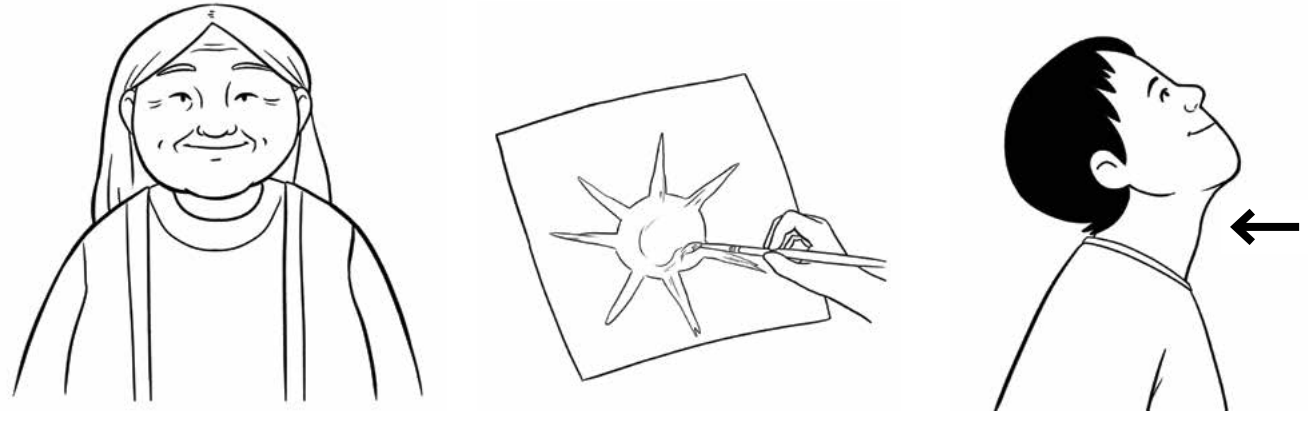

Handwriting practice lines for the Inuktitut letter 'ᑭ'. Each line contains a solid example with stroke direction arrows, a dashed tracing guide, and a series of dots for independent practice.

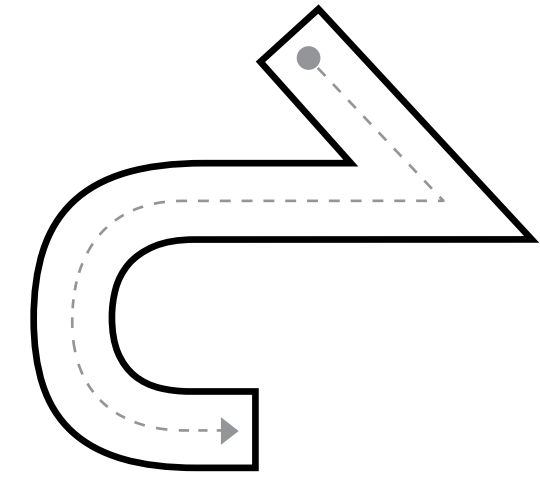

Handwriting practice lines for the Inuktitut letter 'ᑭ'. The first line shows a solid example with stroke direction arrows, followed by dashed tracing guides and a series of dots for independent practice.

